

Kingbright Catalog

2005-2006

P 2-4 SINGLE DIGIT NUMERIC DISPLAYS
P 4-5 DUAL DIGIT NUMERIC DISPLAYS
P 5 THREE DIGIT NUMERIC DISPLAYS
P 5-6 FOUR DIGIT NUMERIC DISPLAYS

P 6-7 ALPHANUMERIC DISPLAYS
P 7-9 DOT MATRIX
P 10-27 PACKAGE DIMENSION

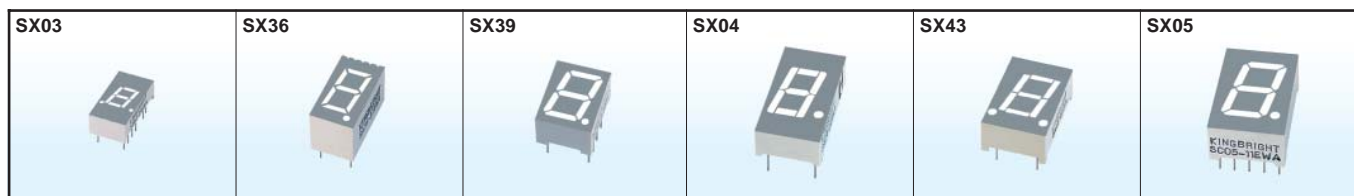

Part No.		Package Description	Material	λ D (nm)	Iv (ucd) @10mA		Package Dimension
Common Anode	Common Cathode				Min.	Typ.	
SA03-11EWA	SC03-12EWA	0.3 inch (7.62mm) Gray Face White Segment	GaAsP/GaP	625	1200	6400	11
SA03-11SRWA	SC03-12SRWA		GaAlAs	640	8000	26000	
SA03-11YWA	SC03-12YWA		GaAsP/GaP	588	800	3000	
SA03-11GWA	SC03-12GWA		GaP	568	1900	8000	
SA36-11EWA	SC36-11EWA	0.36 inch (9.14mm) Gray Face White Segment	GaAsP/GaP	625	480	1900	12
SA36-11SRWA	SC36-11SRWA		GaAlAs	640	1200	6400	
SA36-11YWA	SC36-11YWA		GaAsP/GaP	588	300	1200	
SA36-11GWA	SC36-11GWA		GaP	568	480	1900	
SA39-11EWA SA39-12EWA	SC39-11EWA SC39-12EWA	0.39 inch (9.9mm) Gray Face White Segment	GaAsP/GaP	625	800	4100	13
SA39-11SRWA SA39-12SRWA	SC39-11SRWA SC39-12SRWA		GaAlAs	640	3000	16000	
SA39-11YWA SA39-12YWA	SC39-11YWA SC39-12YWA		GaAsP/GaP	588	800	3000	
SA39-11GWA SA39-12GWA	SC39-11GWA SC39-12GWA		GaP	568	1200	6400	
SA04-11EWA SA04-12EWA	SC04-11EWA SC04-12EWA	0.4 inch (10.16mm) Gray Face White Segment	GaAsP/GaP	625	1900	8000	14
SA04-11SRWA SA04-12SRWA	SC04-11SRWA SC04-12SRWA		GaAlAs	640	4700	18000	
SA04-11YWA SA04-12YWA	SC04-11YWA SC04-12YWA		GaAsP/GaP	588	1200	4700	
SA04-11GWA SA04-12GWA	SC04-11GWA SC04-12GWA		GaP	568	3000	12000	
SA43-11EWA SA43-13EWA	SC43-11EWA SC43-13EWA	0.43 inch (10.92mm) Gray Face White Segment	GaAsP/GaP	625	1200	4700	15
SA43-11SRWA SA43-13SRWA	SC43-11SRWA SC43-13SRWA		GaAlAs	640	4700	18000	
SA43-11YWA SA43-13YWA	SC43-11YWA SC43-13YWA		GaAsP/GaP	588	800	3000	
SA43-11GWA SA43-13GWA	SC43-11GWA SC43-13GWA		GaP	568	1200	6400	
SA05-11EWA	SC05-11EWA	0.5 inch (12.7mm) Gray Face White Segment	GaAsP/GaP	625	1900	8000	16
SA05-11SRWA	SC05-11SRWA		GaAlAs	640	4700	24000	
SA05-11YWA	SC05-11YWA		GaAsP/GaP	588	1200	4700	
SA05-11GWA	SC05-11GWA		GaP	568	1900	10500	

NOTES:

1. All dimensions are in millimeters(inches).
2. Tolerance is ±0.25mm(0.01") unless otherwise noted.

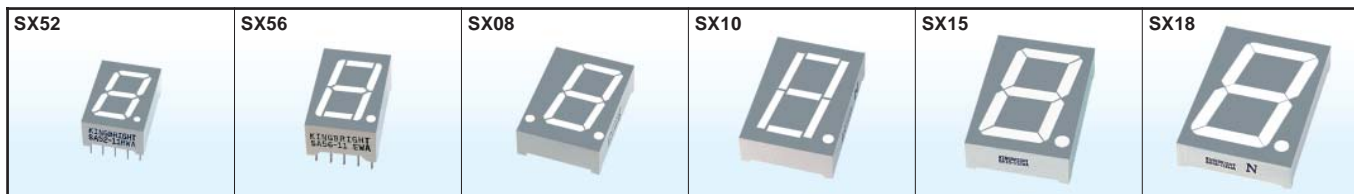

Part No.		Package Description	Material	λ D (nm)	Iv (ucd) @10mA		Package Dimension
Common Anode	Common Cathode				Min.	Typ.	
SA52-11EWA	SC52-11EWA	0.52 inch (13.2mm) Gray Face White Segment	GaAsP/GaP	625	1200	6400	17
SA52-11SRWA	SC52-11SRWA		GaAlAs	640	4700	24000	
SA52-11YWA	SC52-11YWA		GaAsP/GaP	588	1200	4700	
SA52-11GWA	SC52-11GWA		GaP	568	1900	10500	
SA56-11EWA SA56-21EWA	SC56-11EWA SC56-21EWA	0.56 inch (14.2mm) Gray Face White Segment	GaAsP/GaP	625	1200	6400	18
SA56-11SRWA SA56-21SRWA	SC56-11SRWA SC56-21SRWA		GaAlAs	640	4700	24000	
SA56-11YWA SA56-21YWA	SC56-11YWA SC56-21YWA		GaAsP/GaP	588	1200	4700	
SA56-11GWA SA56-21GWA	SC56-11GWA SC56-21GWA		GaP	568	1900	10500	
SA08-11EWA SA08-12EWA SA08-13EWA SA08-21EWA	SC08-11EWA SC08-12EWA SC08-13EWA SC08-21EWA	0.8 inch (20.32mm) Gray Face White Segment	GaAsP/GaP	625	1200	6400	19
SA08-11SRWA SA08-12SRWA SA08-13SRWA SA08-21SRWA	SC08-11SRWA SC08-12SRWA SC08-13SRWA SC08-21SRWA		GaAlAs	640	4700	24000	
SA08-11YWA SA08-12YWA SA08-13YWA SA08-21YWA	SC08-11YWA SC08-12YWA SC08-13YWA SC08-21YWA		GaAsP/GaP	588	1200	4700	
SA08-11GWA SA08-12GWA SA08-13GWA SA08-21GWA	SC08-11GWA SC08-12GWA SC08-13GWA SC08-21GWA		GaP	568	1900	10500	
SA10-11EWA SA10-21EWA	SC10-11EWA SC10-21EWA	1.0 inch (25.4mm) Gray Face White Segment	GaAsP/GaP	625	3000	16000	20
SA10-11SRWA SA10-21SRWA	SC10-11SRWA SC10-21SRWA		GaAlAs	640	12000	60000	
SA10-11YWA SA10-21YWA	SC10-11YWA SC10-21YWA		GaAsP/GaP	588	1900	10500	
SA10-11GWA SA10-21GWA	SC10-11GWA SC10-21GWA		GaP	568	4700	24000	
SA15-11EWA SA15-11SRWA SA15-11YWA SA15-11GWA	SC15-11EWA SC15-11SRWA SC15-11YWA SC15-11GWA	1.5 inch (38.1mm) Gray Face White Segment	GaAsP/GaP	625	3000	16000	21
			GaAlAs	640	12000	60000	
			GaAsP/GaP	588	1900	8000	
			GaP	568	4700	24000	
SBA15-11EGWA	SBC15-11EGWA		GaAsP/GaP	625	3000	16000	
		GaP	568	4700	24000		
SA18-11EWA SA18-11SRWA SA18-11YWA SA18-11GWA SBA18-11EGWA	SC18-11EWA SC18-11SRWA SC18-11YWA SC18-11GWA SBC18-11EGWA	1.75 inch (44.5mm) Gray Face White Segment	GaAsP/GaP	625	4700	24000	22
			GaAlAs	640	18000	75000	
			GaAsP/GaP	588	1900	8000	
			GaP	568	8000	26000	
			GaAsP/GaP	625	4700	18000	
			GaP	568	8000	26000	

NOTES:

1. All dimensions are in millimeters(inches).
2. Tolerance is ±0.25mm(0.01") unless otherwise noted.

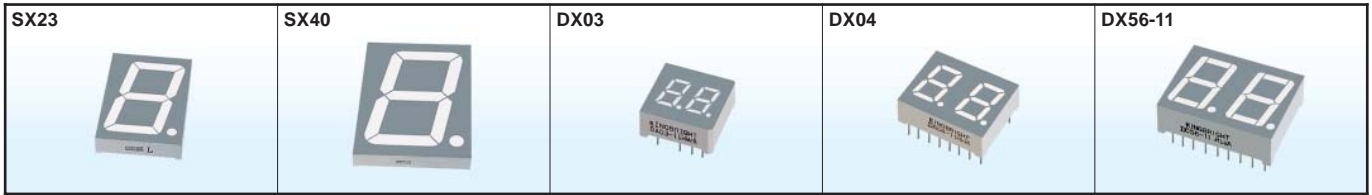

Part No.		Package Description	Material	λ D (nm)	Iv (ucd) @10mA		Package Dimension
Common Anode	Common Cathode				Min.	Typ.	
SA23-11EWA SA23-12EWA	SC23-11EWA SC23-12EWA	2.24 inch (56.9mm) Gray Face White Segment	GaAsP/GaP	625	4700	18000	23
SA23-11SRWA SA23-12SRWA	SC23-11SRWA SC23-12SRWA		GaAlAs	640	18000	75000	
SA23-11YWA SA23-12YWA	SC23-11YWA SC23-12YWA		GaAsP/GaP	588	1900	8000	
SA23-11GWA SA23-12GWA	SC23-11GWA SC23-12GWA		GaP	568	4700	24000	
SBA23-11EGWA	SBC23-11EGWA		GaAsP/GaP	625	4700	18000	
			GaP	568	4700	24000	
SA40-18EWA SA40-19EWA	SC40-18EWA SC40-19EWA	3.984 inch (101.2mm) Gray Face White Segment	GaAsP/GaP	625	12000	44000	24
SA40-18SRWA SA40-19SRWA	SC40-18SRWA SC40-19SRWA		GaAlAs	640	26000	105000	
SA40-18YWA SA40-19YWA	SC40-18YWA SC40-19YWA		GaAsP/GaP	588	8000	26000	
SA40-18GWA SA40-19GWA	SC40-18GWA SC40-19GWA		GaP	568	12000	60000	
DA03-11EWA	DC03-11EWA	0.3 inch (7.62mm) Gray Face White Segment	GaAsP/GaP	625	480	1900	25
DA03-11SRWA	DC03-11SRWA		GaAlAs	640	1900	8000	
DA03-11YWA	DC03-11YWA		GaAsP/GaP	588	300	1200	
DA03-11GWA	DC03-11GWA		GaP	568	800	3000	
DA04-11EWA	DC04-11EWA	0.394 inch (10mm) Gray Face White Segment	GaAsP/GaP	625	1200	4700	26
DA04-11SRWA	DC04-11SRWA		GaAlAs	640	4700	18000	
DA04-11YWA	DC04-11YWA		GaAsP/GaP	588	800	3000	
DA04-11GWA	DC04-11GWA		GaP	568	1900	8000	
DA56-11EWA	DC56-11EWA	0.56 inch (14.22mm) Gray Face White Segment	GaAsP/GaP	625	1900	8000	27
DA56-11SRWA	DC56-11SRWA		GaAlAs	640	4700	24000	
DA56-11YWA	DC56-11YWA		GaAsP/GaP	588	1200	4700	
DA56-11GWA	DC56-11GWA		GaP	568	1900	10500	

NOTES:

1. All dimensions are in millimeters(inches).
2. Tolerance is ±0.25mm(0.01") unless otherwise noted.

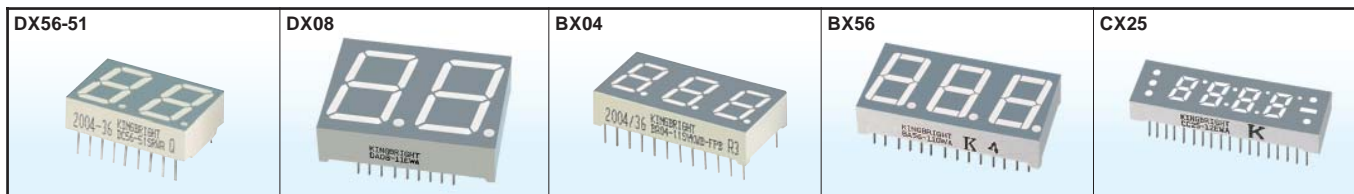

Part No.		Package Description	Material	λ D (nm)	Iv (ucd) @10mA		Package Dimension
Common Anode	Common Cathode				Min.	Typ.	
DA56-51EWA	DC56-51EWA	0.56 inch (14.22mm) Gray Face White Segment	GaAsP/GaP	625	3000	12000	28
DA56-51SRWA	DC56-51SRWA		GaAlAs	640	8000	29500	
DA56-51YWA	DC56-51YWA		GaAsP/GaP	588	1200	5300	
DA56-51GWA	DC56-51GWA		GaP	568	3000	14400	
DA08-11EWA	DC08-11EWA	0.8 inch (20.32mm) Gray Face White Segment	GaAsP/GaP	625	1900	8000	29
DA08-11SRWA	DC08-11SRWA		GaAlAs	640	4700	24000	
DA08-11YWA	DC08-11YWA		GaAsP/GaP	588	1200	4700	
DA08-11GWA	DC08-11GWA		GaP	568	1900	10500	
BA04-11EWA	BC04-11EWA	0.4 inch (10.2mm) Gray Face White Segment	GaAsP/GaP	625	800	4000	30
BA04-11SRWA	BC04-11SRWA		GaAlAs	640	4700	16600	
BA04-11YWA	BC04-11YWA		GaAsP/GaP	588	800	2909	
BA04-11GWA	BC04-11GWA		GaP	568	1200	6100	
BA56-11EWA BA56-12EWA BA56-13EWA	BC56-11EWA BC56-12EWA BC56-13EWA	0.56 inch (14.22mm) Gray Face White Segment	GaAsP/GaP	625	1200	6400	31
BA56-11SRWA BA56-12SRWA BA56-13SRWA	BC56-11SRWA BC56-12SRWA BC56-13SRWA		GaAlAs	640	4700	24000	
BA56-11YWA BA56-12YWA BA56-13YWA	BC56-11YWA BC56-12YWA BC56-13YWA		GaAsP/GaP	588	1200	4700	
BA56-11GWA BA56-12GWA BA56-13GWA	BC56-11GWA BC56-12GWA BC56-13GWA		GaP	568	1900	10500	
CA25-11EWA CA25-12EWA	CC25-11EWA CC25-12EWA	0.244 inch (6.2mm) Gray Face White Segment	GaAsP/GaP	625	1200	6400	32
CA25-11YWA CA25-12YWA	CC25-11YWA CC25-12YWA		GaAsP/GaP	588	800	3000	
CA25-11GWA CA25-12GWA	CC25-11GWA CC25-12GWA		GaP	568	1900	10500	

NOTES:

1. All dimensions are in millimeters(inches).
2. Tolerance is ±0.25mm(0.01") unless otherwise noted.

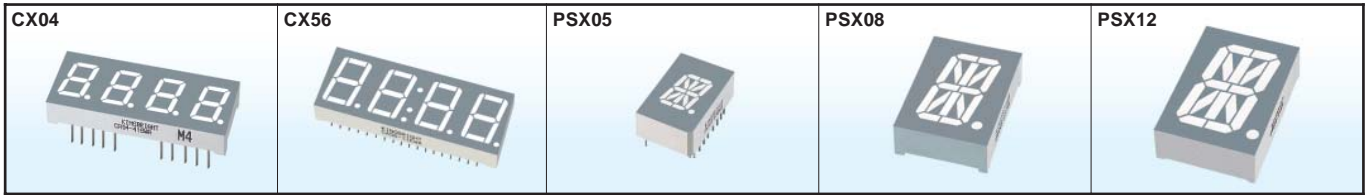

Part No.		Package Description	Material	λ D (nm)	Iv (ucd) @10mA		Package Dimension
Common Anode	Common Cathode				Min.	Typ.	
CA04-41EWA	CC04-41EWA	0.4 inch (10.16mm) Gray Face White Segment	GaAsP/GaP	625	1200	4700	33
CA04-41SRWA	CC04-41SRWA		GaAlAs	640	4700	18000	
CA04-41YWA	CC04-41YWA		GaAsP/GaP	588	1200	4700	
CA04-41GWA	CC04-41GWA		GaP	568	1200	6400	
CA56-11EWA CA56-12EWA CA56-21EWA	CC56-11EWA CC56-12EWA CC56-21EWA	0.56 inch (14.22mm) Gray Face White Segment	GaAsP/GaP	625	1200	6400	34
CA56-11SRWA CA56-12SRWA CA56-21SRWA	CC56-11SRWA CC56-12SRWA CC56-21SRWA		GaAlAs	640	4700	24000	
CA56-11YWA CA56-12YWA CA56-21YWA	CC56-11YWA CC56-12YWA CC56-21YWA		GaAsP/GaP	588	1200	4700	
CA56-11GWA CA56-12GWA CA56-21GWA	CC56-11GWA CC56-12GWA CC56-21GWA		GaP	568	1900	10500	
PSA05-11EWA PSA05-12EWA	PSC05-11EWA PSC05-12EWA	0.5 inch (12.7mm) Gray Face White Segment	GaAsP/GaP	625	800	4100	35
PSA05-11SRWA PSA05-12SRWA	PSC05-11SRWA PSC05-12SRWA		GaAlAs	640	4700	18000	
PSA05-11YWA PSA05-12YWA	PSC05-11YWA PSC05-12YWA		GaAsP/GaP	588	800	3000	
PSA05-11GWA PSA05-12GWA	PSC05-11GWA PSC05-12GWA		GaP	568	1200	4700	
PSA08-11EWA PSA08-12EWA	PSC08-11EWA PSC08-12EWA	0.8 inch (20.32mm) Gray Face White Segment	GaAsP/GaP	625	1200	4700	36
PSA08-11SRWA PSA08-12SRWA	PSC08-11SRWA PSC08-12SRWA		GaAlAs	640	4700	18000	
PSA08-11YWA PSA08-12YWA	PSC08-11YWA PSC08-12YWA		GaAsP/GaP	588	800	3000	
PSA08-11GWA PSA08-12GWA	PSC08-11GWA PSC08-12GWA		GaP	568	1200	4700	
PSA12-11EWA	PSC12-11EWA	1.2 inch (30.48mm) Gray Face White Segment	GaAsP/GaP	625	3000	12000	37
PSA12-11SRWA	PSC12-11SRWA		GaAlAs	640	8000	26000	
PSA12-11YWA	PSC12-11YWA		GaAsP/GaP	588	1200	4700	
PSA12-11GWA	PSC12-11GWA		GaP	568	3000	12000	

NOTES:

1. All dimensions are in millimeters(inches).
2. Tolerance is ±0.25mm(0.01") unless otherwise noted.

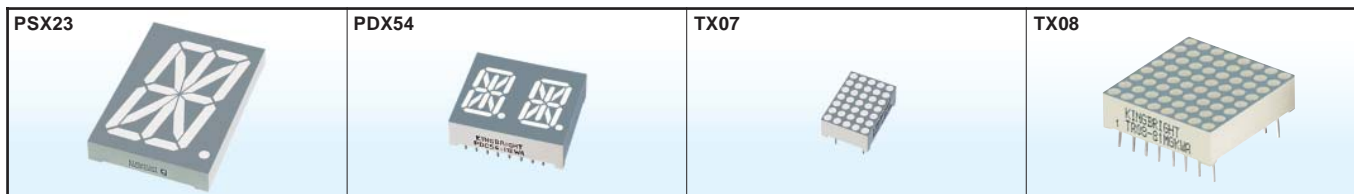

Part No.		Package Description	Material	λ D (nm)	Iv (ucd) @10mA		Package Dimension
Common Anode	Common Cathode				Min.	Typ.	
PSA23-11EWA	PSC23-11EWA	2.24 inch (56.8mm) Gray Face White Segment	GaAsP/GaP	625	1900	8000	38
PSA23-11SRWA	PSC23-11SRWA		GaAlAs	640	12000	75000	
PSA23-11YWA	PSC23-11YWA		GaAsP/GaP	588	1900	8000	
PSA23-11GWA	PSC23-11GWA		GaP	568	1900	10500	
PDA54-11EWA PDA54-12EWA	PDC54-11EWA PDC54-12EWA	0.543 inch (13.8mm) Gray Face White Segment	GaAsP/GaP	625	1200	4700	39
PDA54-11SRWA PDA54-12SRWA	PDC54-11SRWA PDC54-12SRWA		GaAlAs	640	4700	18000	
PDA54-11YWA PDA54-12YWA	PDC54-11YWA PDC54-12YWA		GaAsP/GaP	588	800	3000	
PDA54-11GWA PDA54-12GWA	PDC54-11GWA PDC54-12GWA		GaP	568	1900	8000	

Part No.		Package Description	Material	λ D (nm)	Iv (ucd) @10mA		Package Dimension
Column Anode	Column Cathode				Min.	Typ.	
TA07-11EWA	TC07-11EWA	0.7 inch (18mm) 5x7 Gray Face White Dot	GaAsP/GaP	625	1900	8000	40
TA07-11SRWA	TC07-11SRWA		GaAlAs	640	4700	24000	
TA07-11YWA	TC07-11YWA		GaAsP/GaP	588	1200	4700	
TA07-11GWA	TC07-11GWA		GaP	568	1900	8000	
TA08-81EWA	TC08-81EWA	0.8 inch (20mm) 8x8 Gray Face White Dot	GaAsP/GaP	625	800	3600	41
TA08-81SRWA	TC08-81SRWA		GaAlAs	640	4700	23600	
TA08-81YWA	TC08-81YWA		GaAsP/GaP	588	800	3195	
TA08-81GWA	TC08-81GWA		GaP	568	1200	5600	

NOTES:

1. All dimensions are in millimeters(inches).
2. Tolerance is ±0.25mm(0.01") unless otherwise noted.

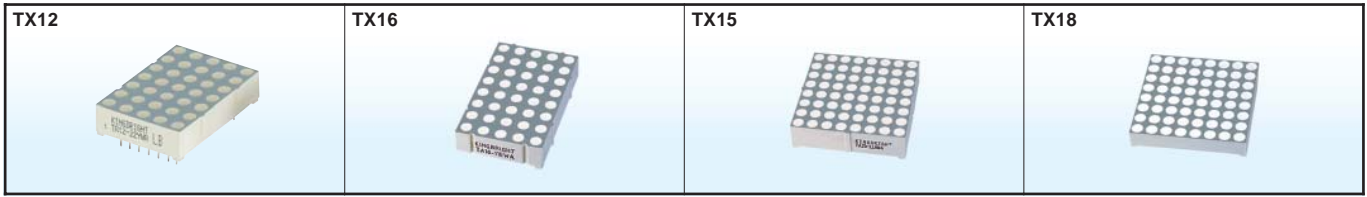

Part No.		Package Description	Material	λ D (nm)	Iv (ucd) @10mA		Package Dimension
Column Anode	Column Cathode				Min.	Typ.	
TA12-11EWA	TC12-11EWA	1.2 inch (30mm) 5x7 Gray Face White Dot	GaAsP/GaP	625	1900	8000	42
TA12-11SRWA	TC12-11SRWA		GaAlAs	640	4700	24000	
TA12-11YWA	TC12-11YWA		GaAsP/GaP	588	1200	4700	
TA12-11GWA	TC12-11GWA		GaP	568	1900	10500	
TA12-22EWA	TC12-22EWA		GaAsP/GaP	625	1900	8000	
TA12-22SRWA	TC12-22SRWA		GaAlAs	640	12000	37800	
TA12-22YWA	TC12-22YWA		GaAsP/GaP	588	1200	5400	
TA12-22GWA	TC12-22GWA		GaP	568	3000	15033	
TBA12-11EGWA	TBC12-11EGWA		GaAsP/GaP	625	1900	8000	
			GaP	568	1900	10500	
TBA12-12EGWA	TBC12-12EGWA		GaAsP/GaP	625	1900	8000	
			GaP	568	1900	10500	
TBA12-22EGWA	TBC12-22EGWA	GaAsP/GaP	625	1900	8000		
		GaP	568	1900	10500		
TA16-11EWA	TC16-11EWA	1.4 inch (37mm) 5x8 Gray Face White Dot	GaAsP/GaP	625	1900	8000	43
TA16-11SRWA	TC16-11SRWA		GaAlAs	640	4700	24000	
TA16-11YWA	TC16-11YWA		GaAsP/GaP	588	1200	4700	
TA16-11GWA	TC16-11GWA		GaP	568	3000	12000	
TA15-11EWA	TC15-11EWA	1.5 inch (38mm) 8x8 Gray Face White Dot	GaAsP/GaP	625	1900	10500	44
TA15-11SRWA	TC15-11SRWA		GaAlAs	640	8000	26000	
TA15-11YWA	TC15-11YWA		GaAsP/GaP	588	1900	8000	
TA15-11GWA	TC15-11GWA		GaP	568	3000	16000	
TBA15-11EGWA	TBC15-11EGWA		GaAsP/GaP	625	1900	10500	
		GaP	568	3000	16000		
TA18-81EWA	TC18-81EWA	1.85 inch (47mm) 8x8 Gray Face White Dot	GaAsP/GaP	625	4700	19650	45
TA18-81SRWA	TC18-81SRWA		GaAlAs	640	12000	44000	
TA18-81YWA	TC18-81YWA		GaAsP/GaP	588	3000	14850	
TA18-81GWA	TC18-81GWA		GaP	568	8000	29200	

NOTES:

1. All dimensions are in millimeters(inches).
2. Tolerance is ±0.25mm(0.01") unless otherwise noted.



Part No.		Package Description	Material	λ D (nm)	Iv (ucd) @10mA		Package Dimension
Column Anode	Column Cathode				Min.	Typ.	
TA20-11EWA	TC20-11EWA	2.0 inch (50mm) 5x7 Gray Face White Dot	GaAsP/GaP	625	3000	12000	46
TA20-11SRWA	TC20-11SRWA		GaAlAs	640	8000	26000	
TA20-11YWA	TC20-11YWA		GaAsP/GaP	588	1900	8000	
TA20-11GWA	TC20-11GWA		GaP	568	3000	16000	
TBA20-11EGWA	TBC20-11EGWA		GaAsP/GaP	625	3000	12000	
TBA20-12EGWA	TBC20-12EGWA		GaP	568	3000	16000	
TBA20-22EGWA	TBC20-22EGWA		GaAsP/GaP	625	3000	12000	
TBA20-22EGWA	TBC20-22EGWA		GaP	568	3000	16000	
TA23-11EWA	TC23-11EWA	2.3 inch (58mm) 8x8 Gray Face White Dot	GaAsP/GaP	625	1900	8000	47
TA23-11SRWA	TC23-11SRWA		GaAlAs	640	12000	44000	
TA23-11YWA	TC23-11YWA		GaAsP/GaP	588	1900	8000	
TA23-11GWA	TC23-11GWA		GaP	568	1900	10500	
TBA23-11EGWA	TBC23-11EGWA		GaAsP/GaP	625	1900	8000	
TBA23-12EGWA	TBC23-12EGWA		GaP	568	1900	10500	
TBA23-12EGWA	TBC23-12EGWA		GaAsP/GaP	625	1900	8000	
TBA23-12EGWA	TBC23-12EGWA		GaP	568	1900	10500	
TA24-11EWA	TC24-11EWA	2.4 inch (60.8mm) 5x8 Gray Face White Dot	GaAsP/GaP	625	1900	8000	48
TA24-11SRWA	TC24-11SRWA		GaAlAs	640	8000	26000	
TA24-11YWA	TC24-11YWA		GaAsP/GaP	588	1900	8000	
TA24-11GWA	TC24-11GWA		GaP	568	3000	12000	
TBA24-11EGWA	TBC24-11EGWA		GaAsP/GaP	625	1900	8000	
TBA24-12EGWA	TBC24-12EGWA		GaP	568	3000	12000	
TBA24-22EGWA	TBC24-22EGWA		GaAsP/GaP	625	1900	8000	
TBA24-22EGWA	TBC24-22EGWA		GaP	568	3000	12000	
TA30-11EWA	TC30-11EWA	3.0 inch (76.2mm) 5x7 Gray Face White Dot	GaAsP/GaP	625	8000	32000	49
TA30-11SRWA	TC30-11SRWA		GaAlAs	640	18000	88000	
TA30-11YWA	TC30-11YWA		GaAsP/GaP	588	8000	28570	
TA30-11GWA	TC30-11GWA		GaP	568	12000	56100	
TA40-11EWA	TC40-11EWA	4.0 inch (100mm) 5x7 Gray Face White Dot	GaAsP/GaP	625	3000	16000	50
TA40-11SRWA	TC40-11SRWA		GaAlAs	640	12000	44000	
TA40-11YWA	TC40-11YWA		GaAsP/GaP	588	1900	8000	
TA40-11GWA	TC40-11GWA		GaP	568	4700	24000	
TBA40-11EGWA	TBC40-11EGWA		GaAsP/GaP	625	3000	16000	
TBA40-12EGWA	TBC40-12EGWA		GaP	568	8000	24000	
TBA40-12EGWA	TBC40-12EGWA		GaAsP/GaP	625	3000	16000	
TBA40-12EGWA	TBC40-12EGWA		GaP	568	4700	24000	

NOTES:

1. All dimensions are in millimeters(inches).
2. Tolerance is ±0.25mm(0.01") unless otherwise noted.

SA/SC03 Series

11

A: SA03-11
B: SC03-12

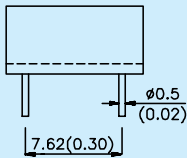
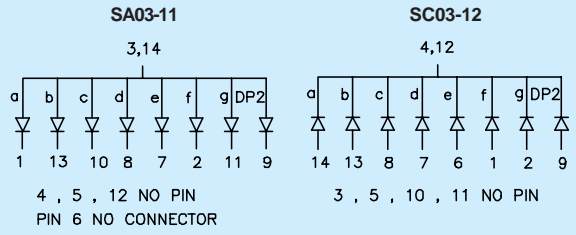
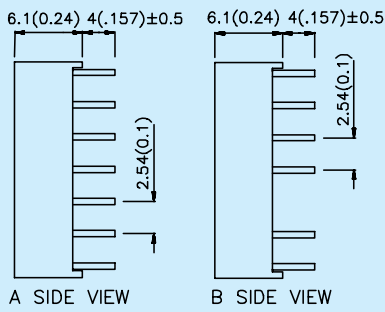
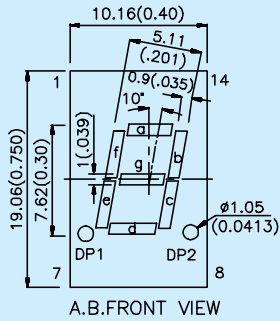

SA/SC36 Series

12

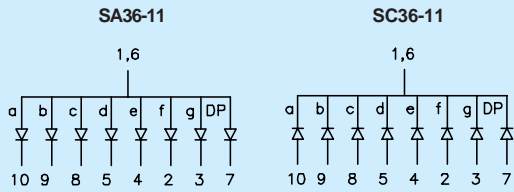
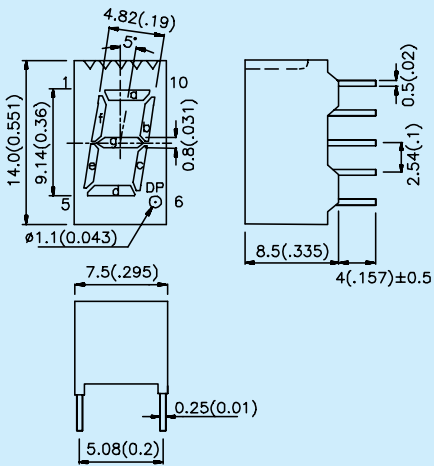

SA/SC39 Series

13

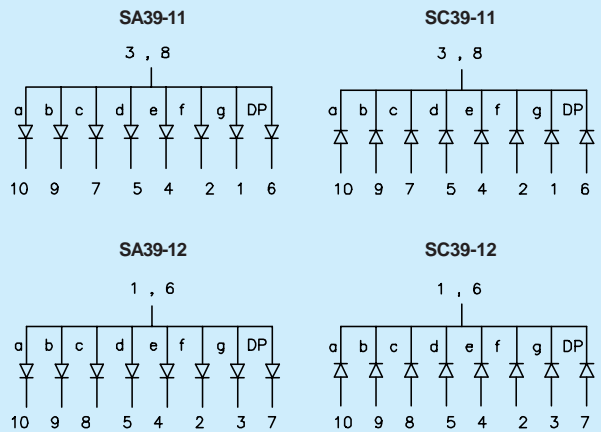
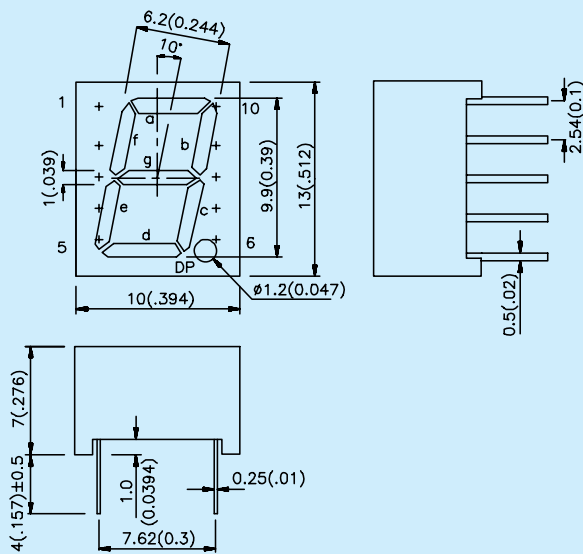

NOTES:

1. All dimensions are in millimeters(inches).
2. Tolerance is ±0.25mm(0.01") unless otherwise noted.

SA/SC04 Series

- A: SA04-11
- B: SC04-11
- C: SA/SC04-12

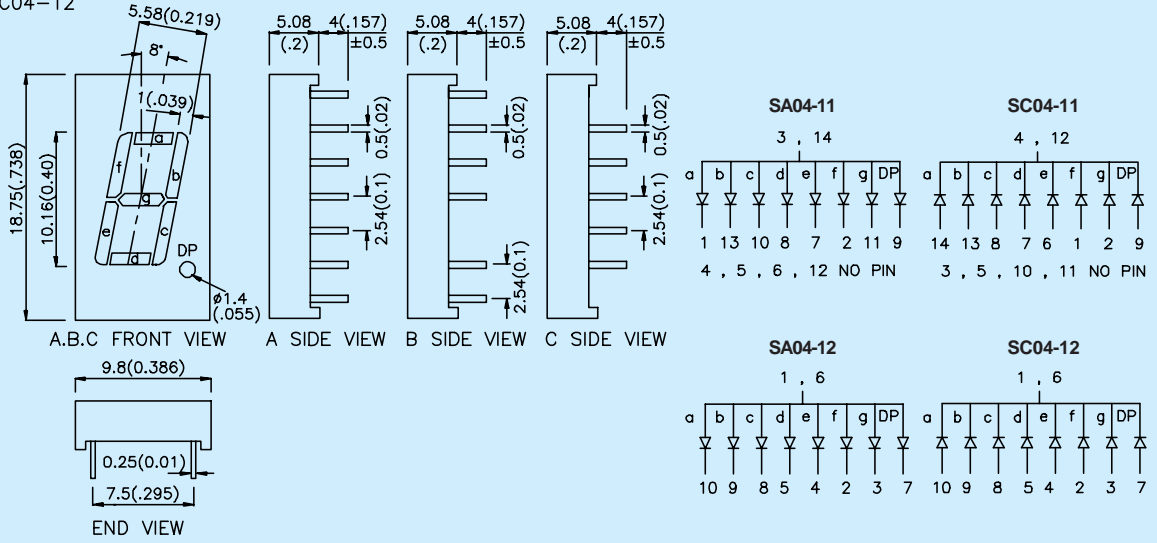

SA/SC43 Series

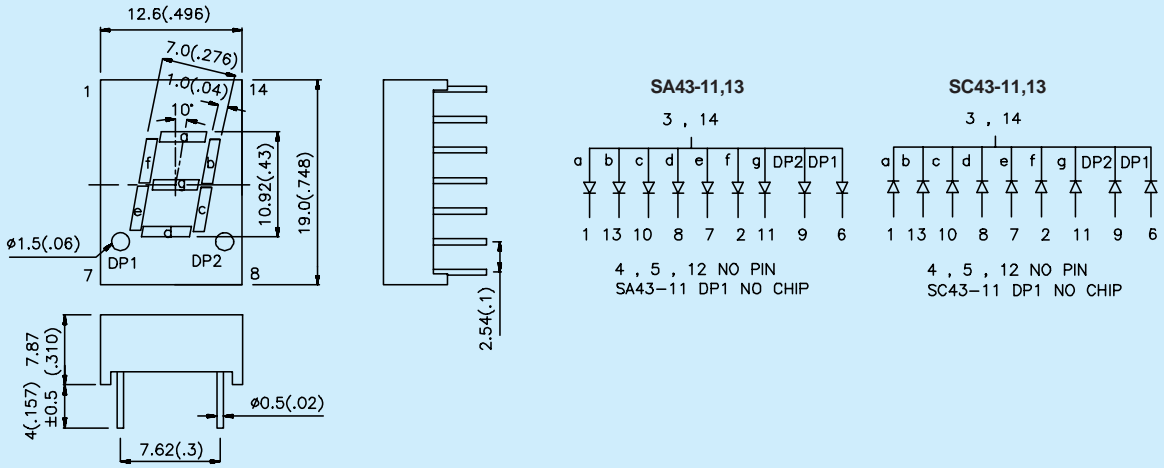

SA/SC05 Series

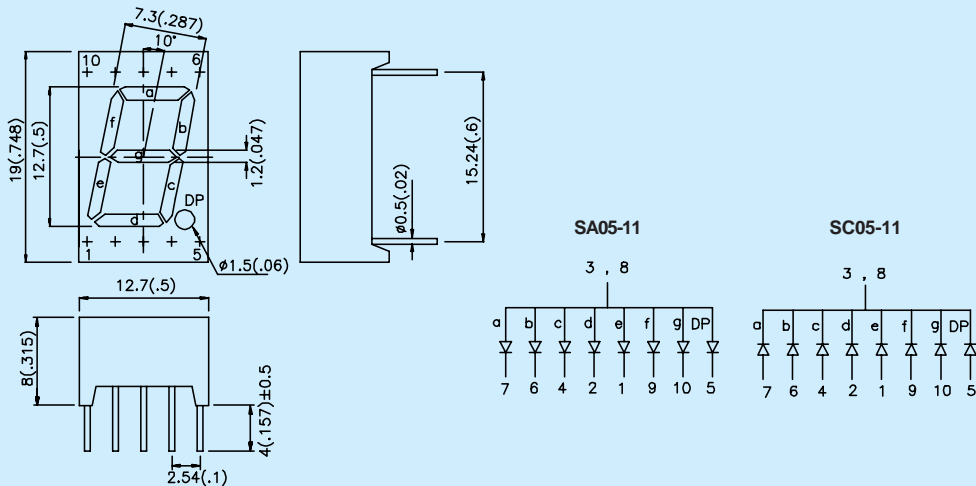

NOTES:
1. All dimensions are in millimeters (inches).
2. Tolerance is ±0.25mm (0.01") unless otherwise noted.

SA/SC52 Series

17

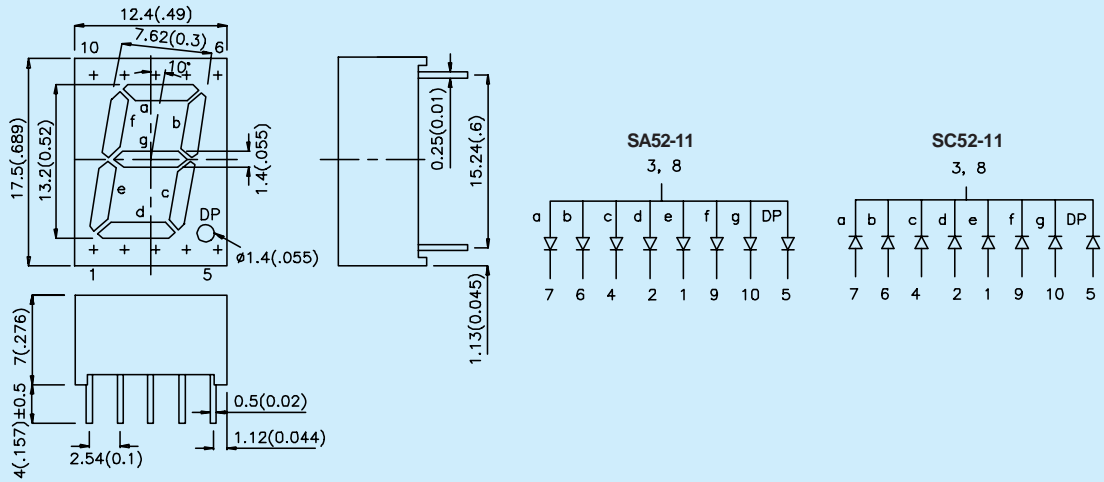

SA/SC56 Series

18

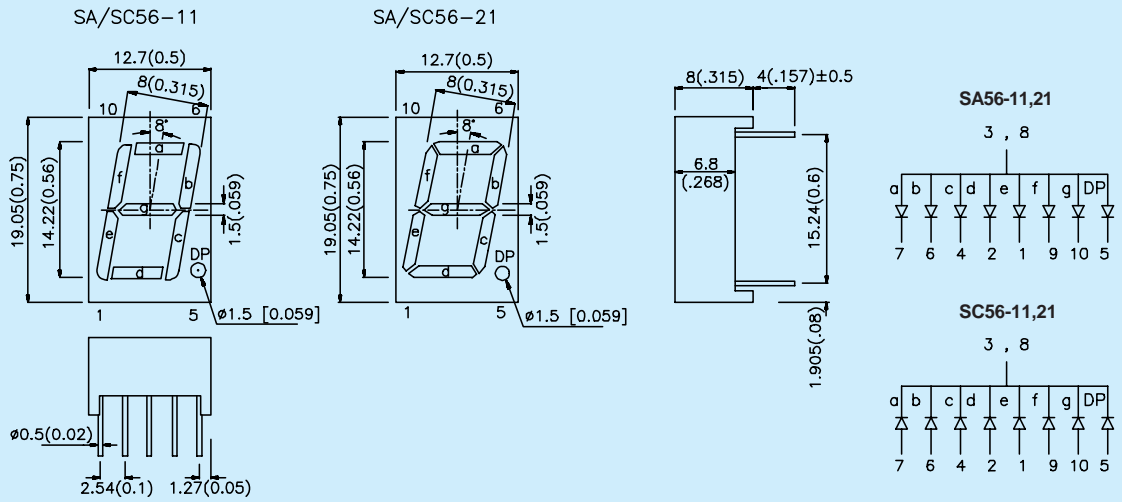

SA/SC08 Series

19

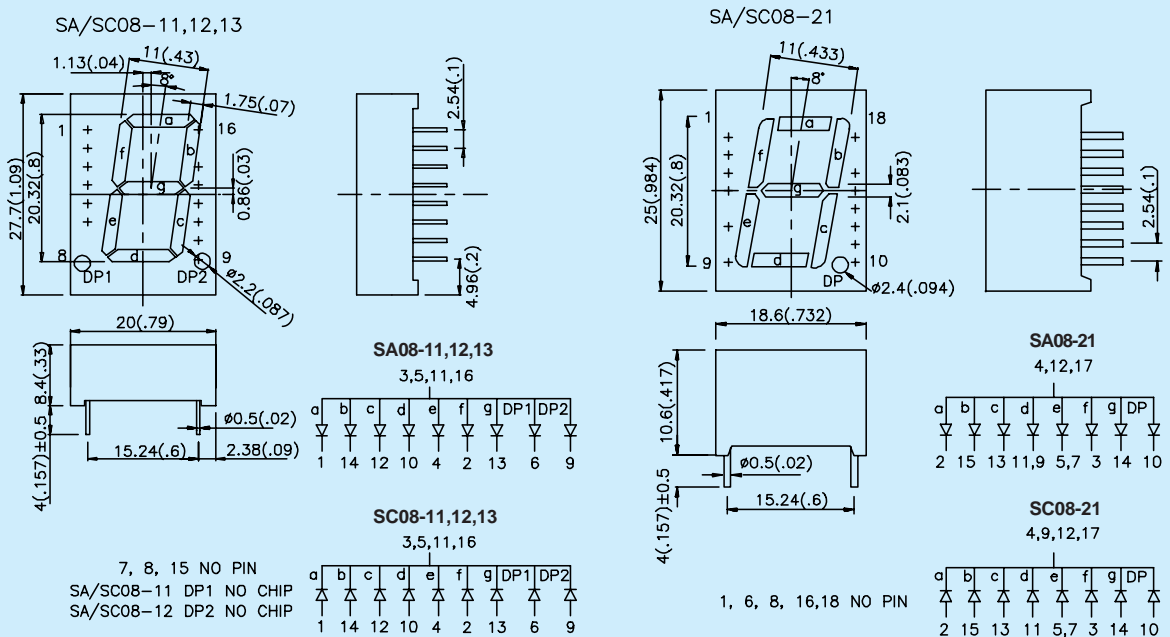

NOTES:
 1. All dimensions are in millimeters(inches).
 2. Tolerance is $\pm 0.25\text{mm}(0.01")$ unless otherwise noted.

SA/SC10 Series

20

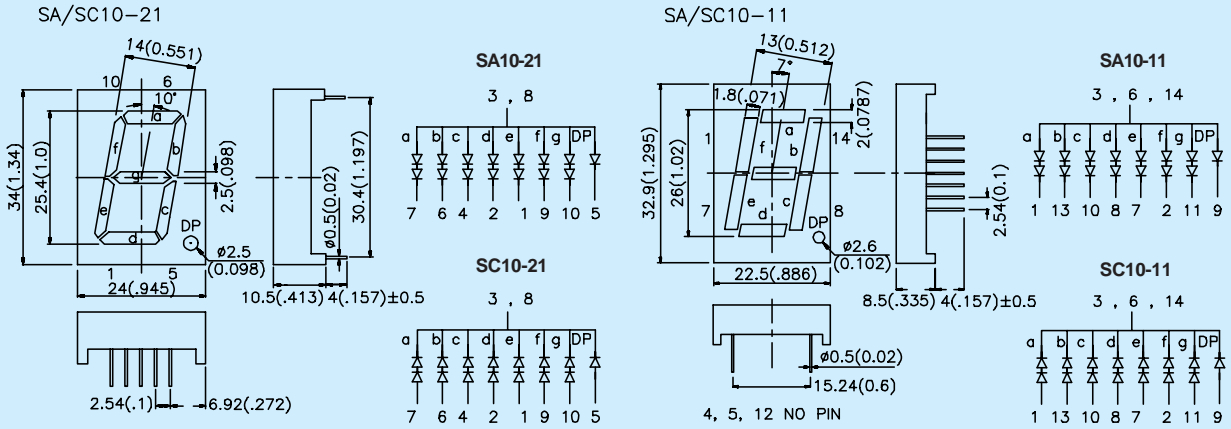

SA/SC15, SBA/SBC15 Series

21

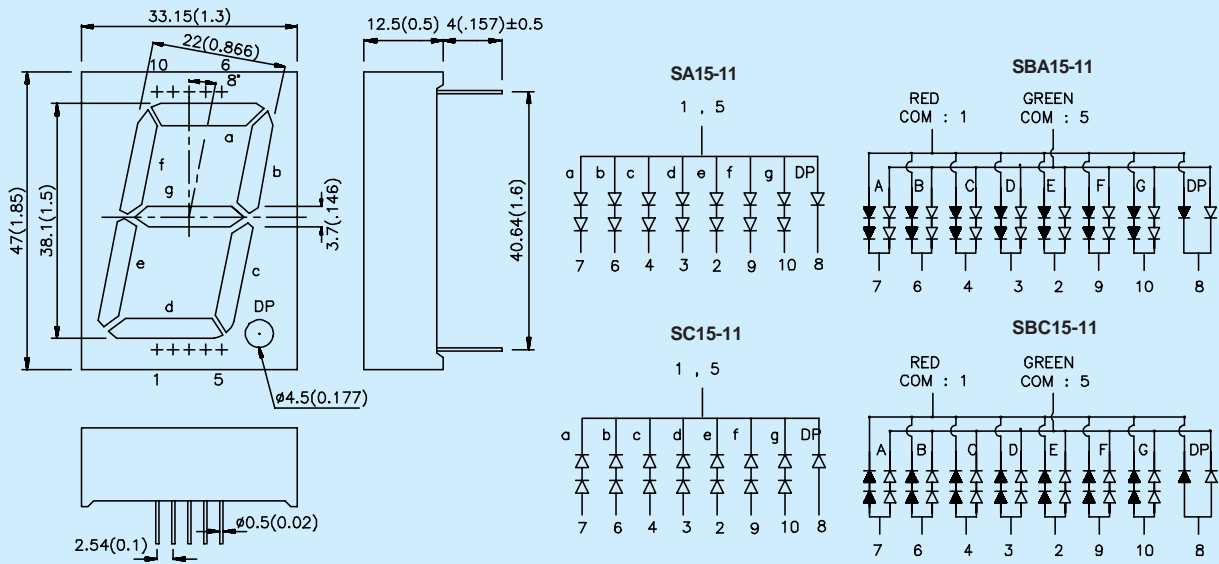

SA/SC18, SBA/SBC18 Series

22

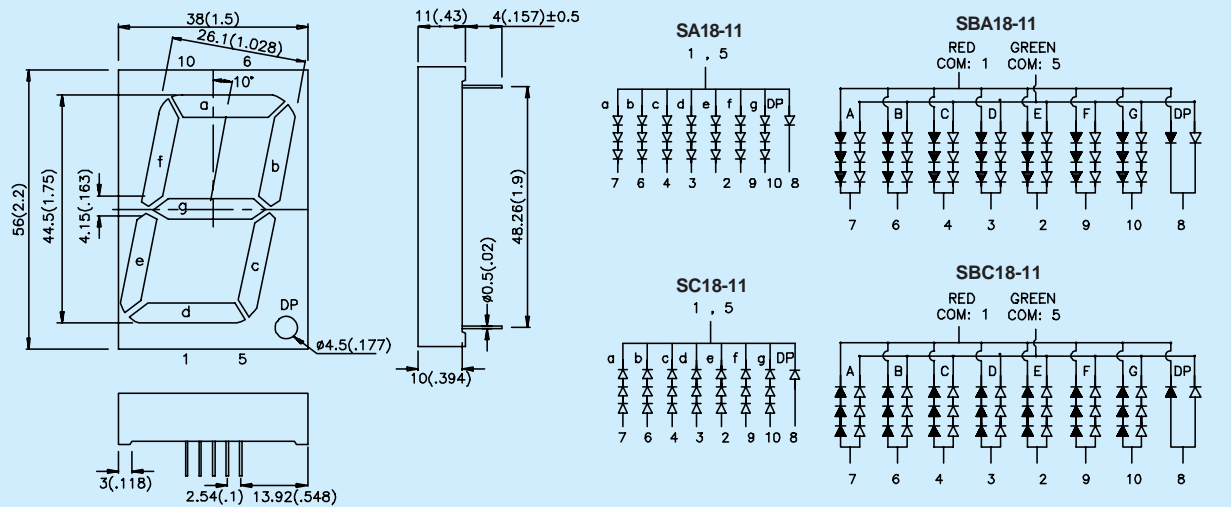

NOTES:
 1. All dimensions are in millimeters(inches).
 2. Tolerance is ±0.25mm(0.01") unless otherwise noted.

SA/SC23,SBA/SBC23 Series

23

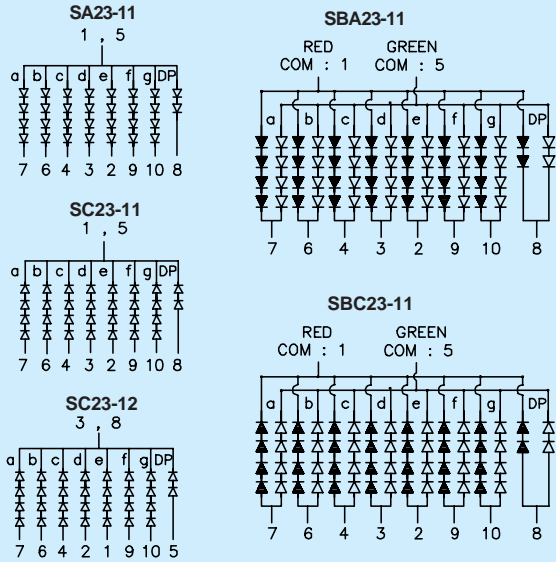
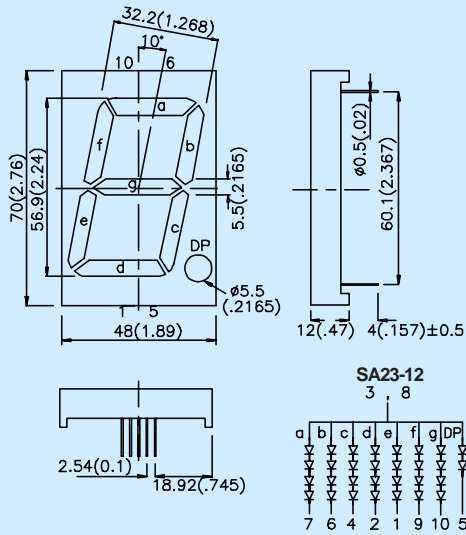

SA/SC40 Series

24

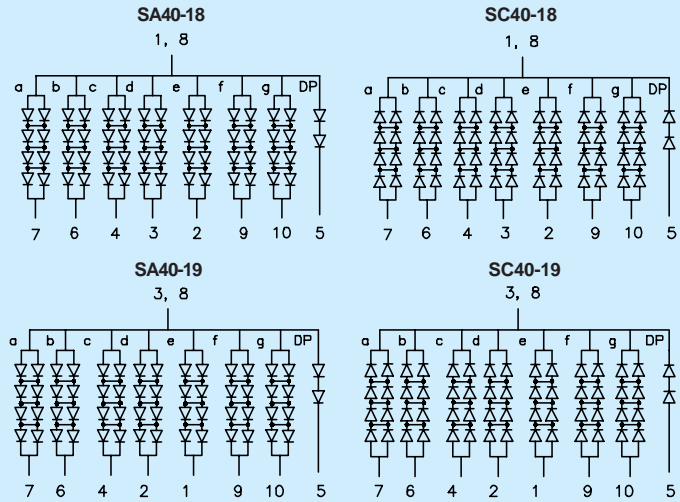
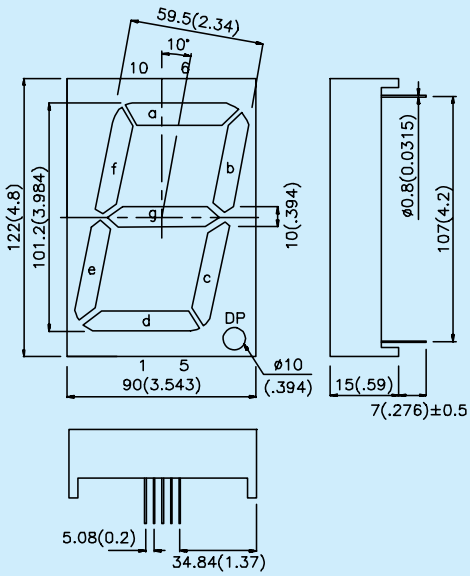

DA/DC03 Series

25

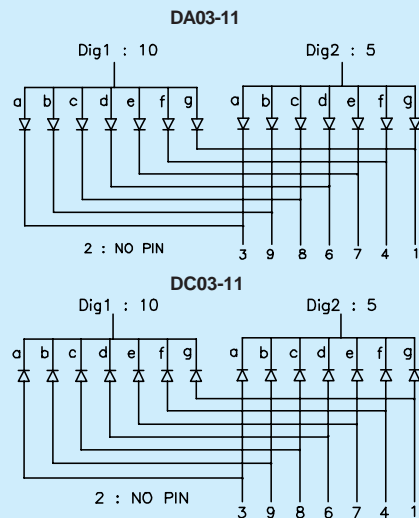
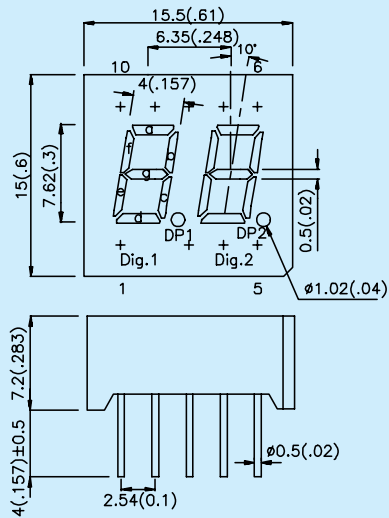

NOTES:
 1. All dimensions are in millimeters(inches).
 2. Tolerance is $\pm 0.25\text{mm}(0.01")$ unless otherwise noted.

DA/DC04 Series

26

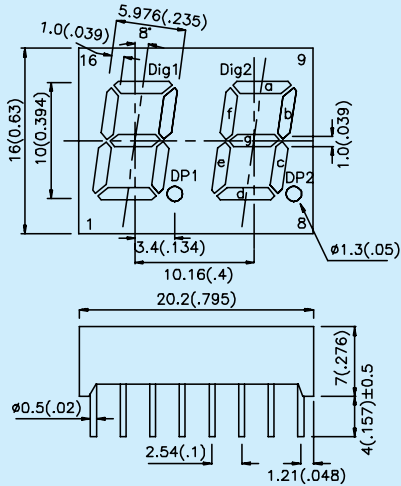

DA04-11

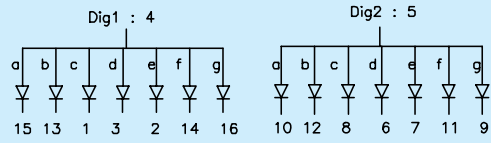

DC04-11

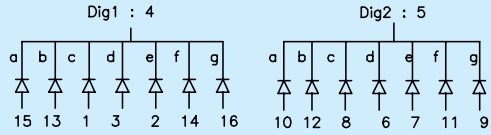

DA/DC56 Series

27

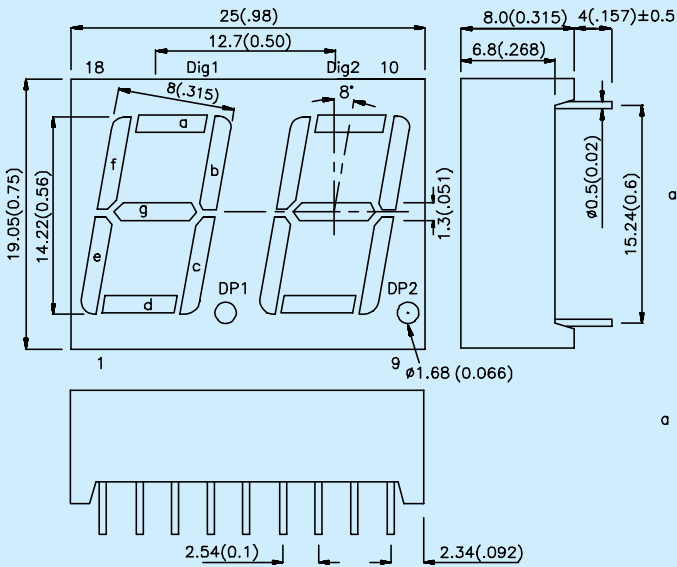

DA56-11

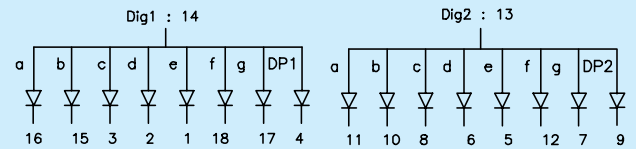

DC56-11

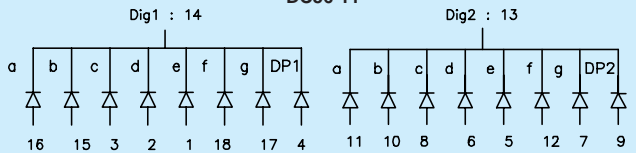

DA/DC56 Series

28

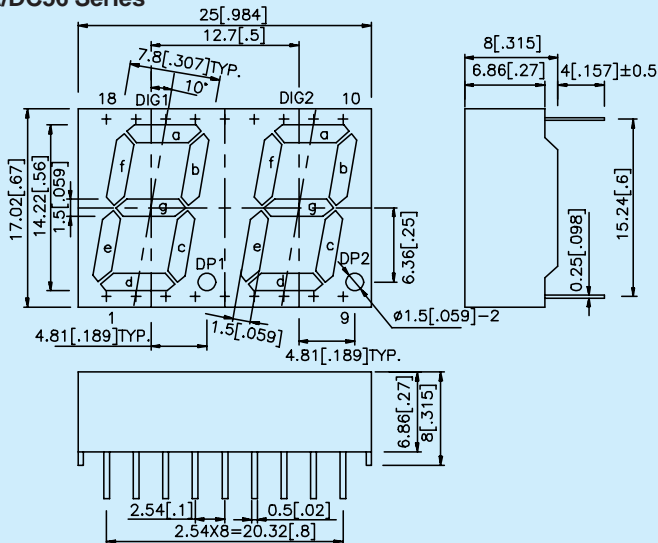

DA56-51

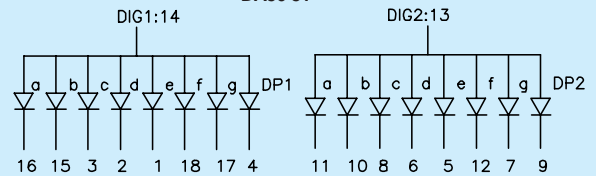

DC56-51

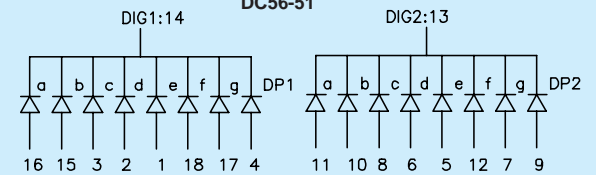

NOTES:

1. All dimensions are in millimeters(inches).
2. Tolerance is ±0.25mm(0.01") unless otherwise noted.

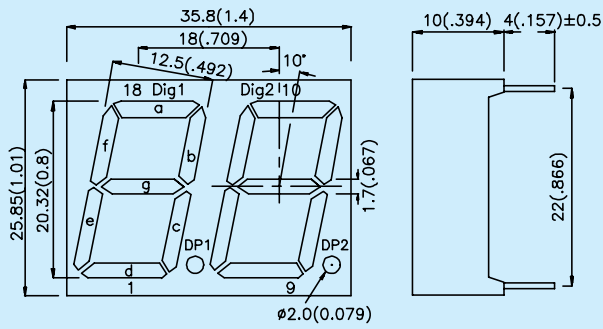

DA08-11

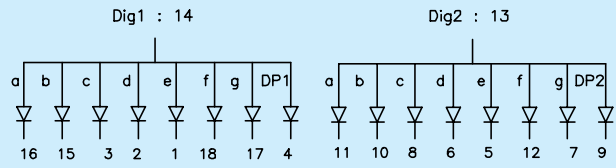

DC08-11

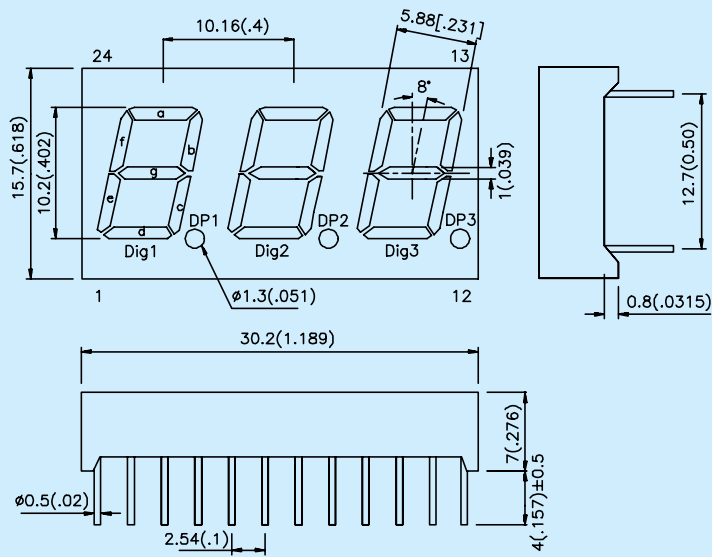
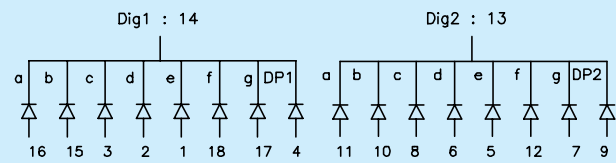

BA04-11

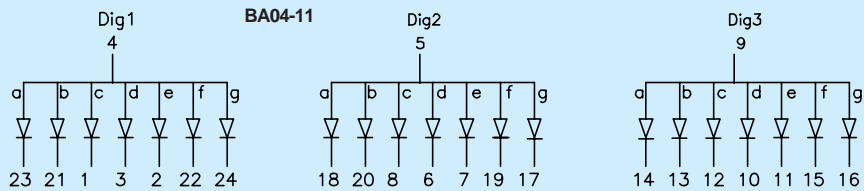

BC04-11

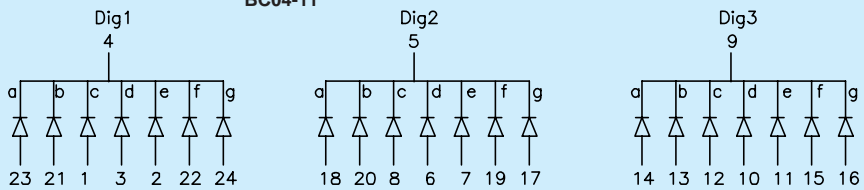

NOTES:

1. All dimensions are in millimeters(inches).
2. Tolerance is $\pm 0.25\text{mm}(0.01")$ unless otherwise noted.

BA/BC56 Series

BA/BC56-11
BA/BC56-13

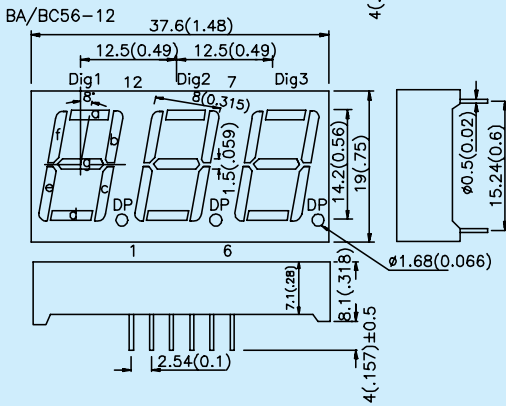
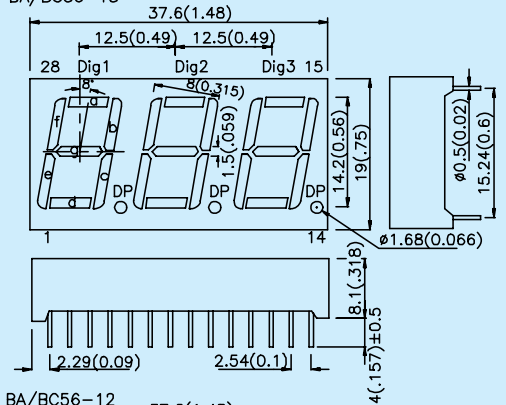

BA56-11

Dig1: 3,26
Dig2: 19
Dig3: 18

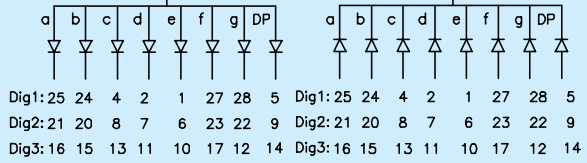

BC56-11

Dig1: 3,26
Dig2: 19
Dig3: 18

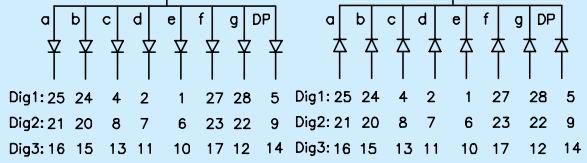

BA56-13

Dig1: 26
Dig2: 8,21
Dig3: 15

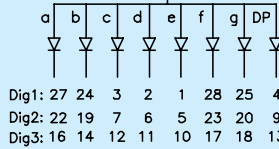

BC56-13

Dig1: 26
Dig2: 8,21
Dig3: 15

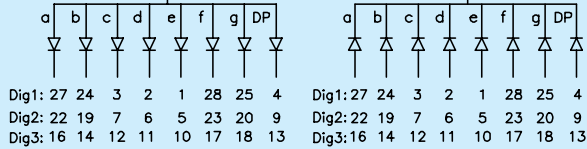

BA56-12

Dig1: 12
Dig2: 9
Dig3: 8

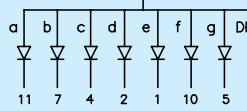

BC56-12

Dig1: 12
Dig2: 9
Dig3: 8

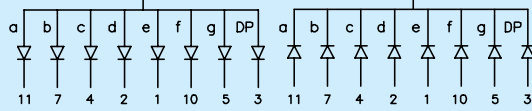

CA/CC25 Series

A: CA/CC25-11
B: CA/CC25-12

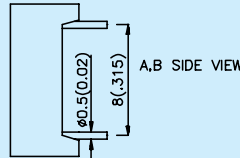
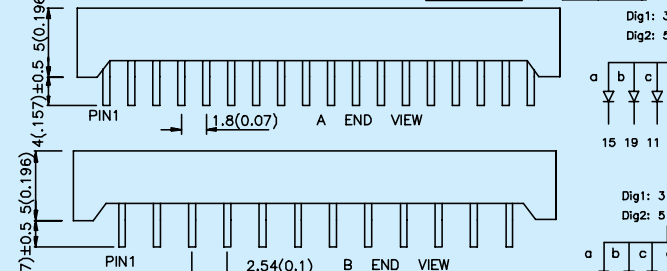
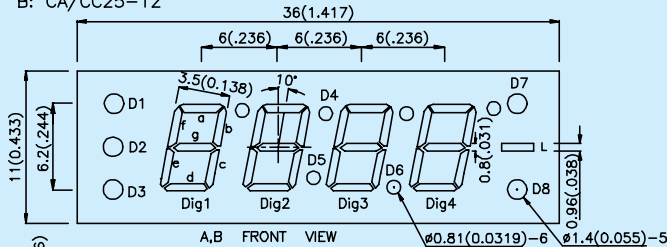

CA25-12

Dig1: 3 Dig3: 8
Dig2: 5 Dig4: 10

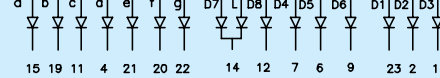

CC25-12

Dig1: 3 Dig3: 8
Dig2: 5 Dig4: 10

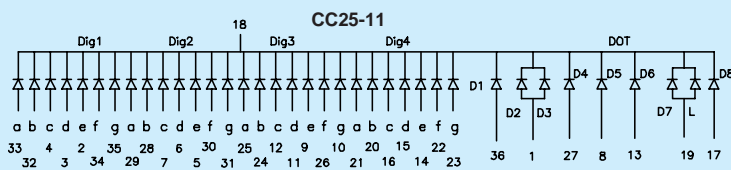
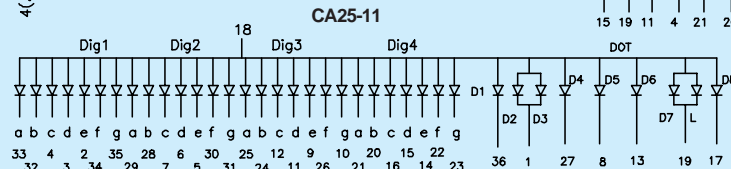
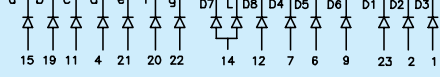

NOTES:
1. All dimensions are in millimeters(inches).
2. Tolerance is ±0.25mm(0.01") unless otherwise noted.

CA/CC04 Series

33

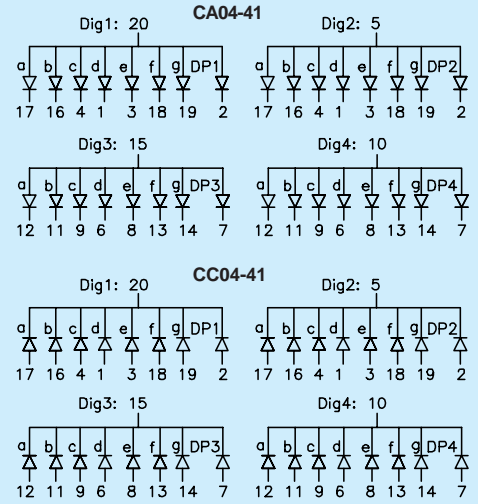
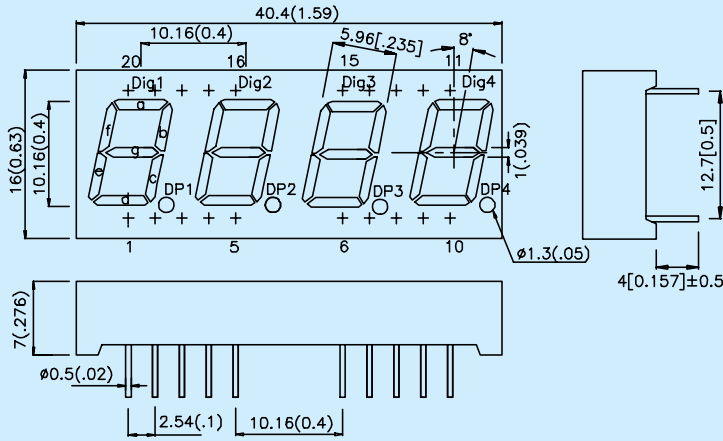

CA/CC56 Series

34

- A: CA/CC56-11
- B: CA/CC56-12
- C: CA/CC56-21

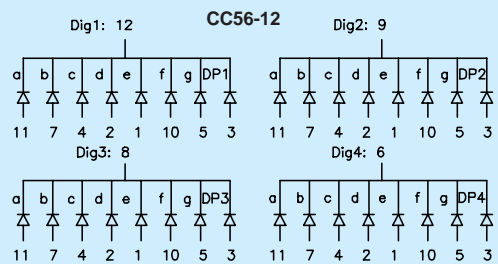
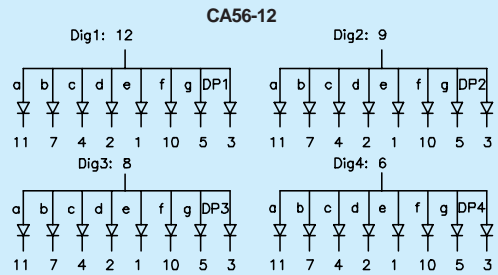
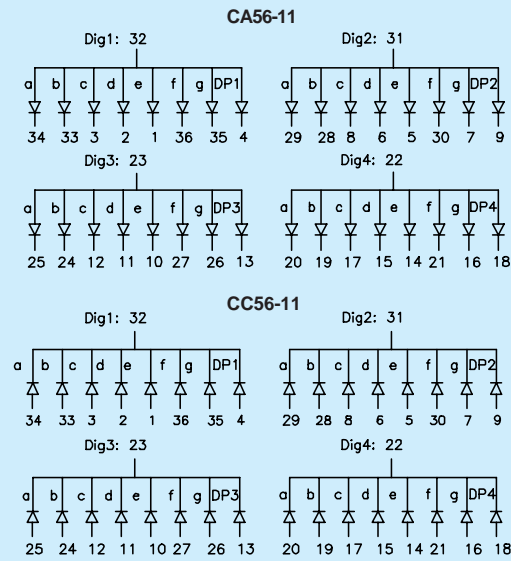
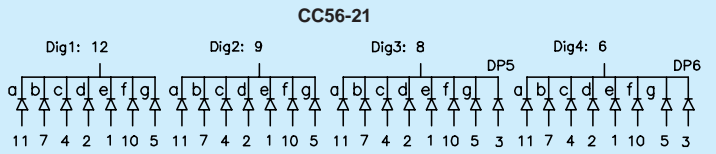
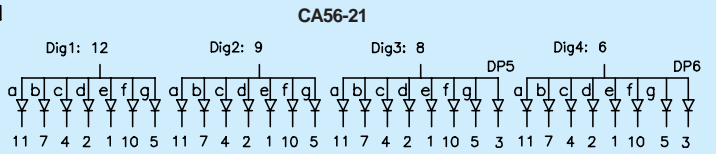
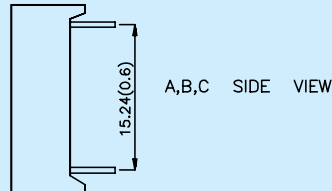
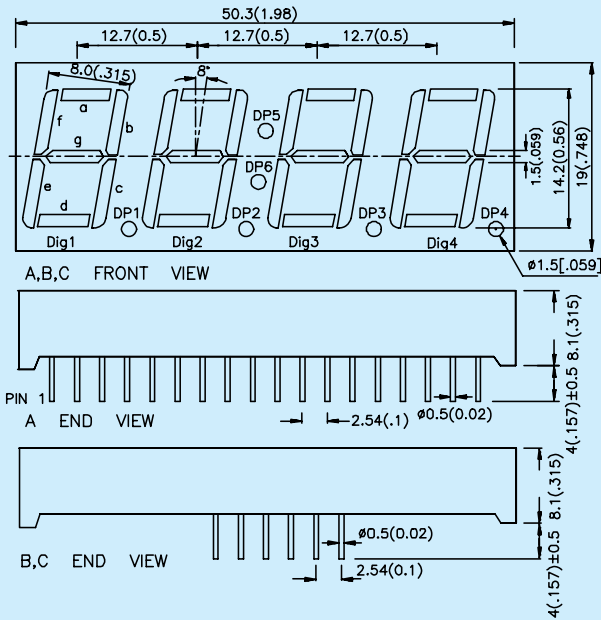

NOTES:
 1. All dimensions are in millimeters(inches).
 2. Tolerance is ±0.25mm(0.01") unless otherwise noted.

PSA/PSC05 Series

35

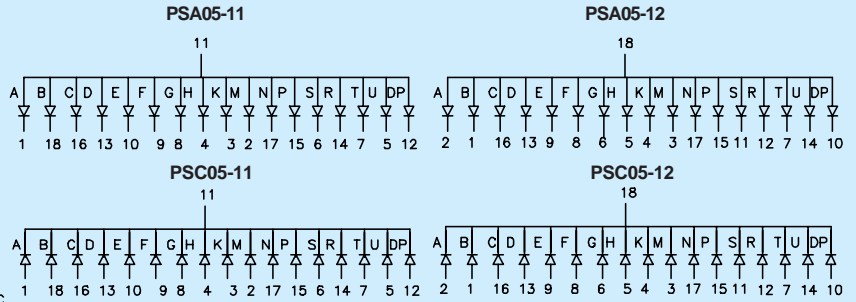
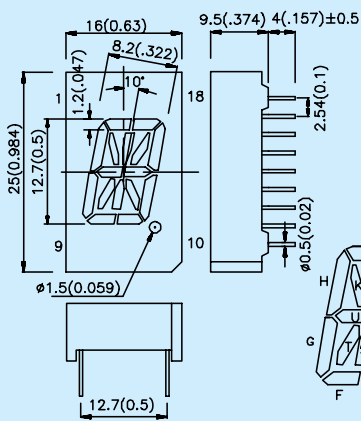

PSA/PSC08 Series

36

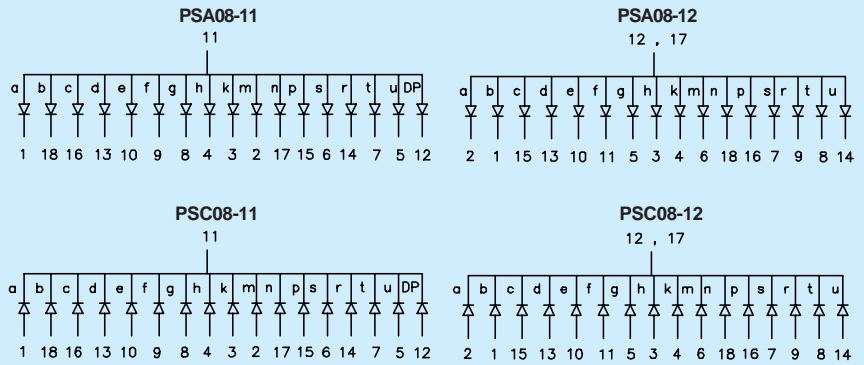
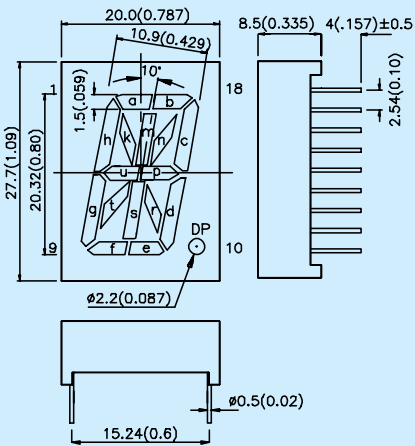

PSA/PSC12 Series

37

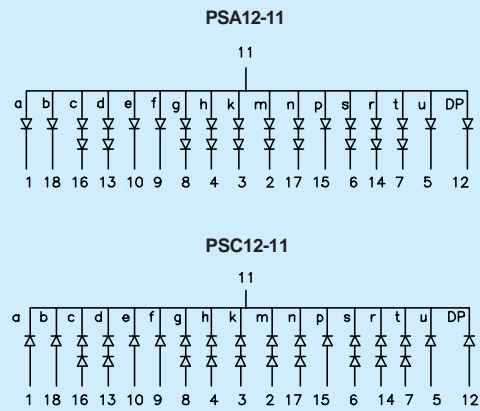
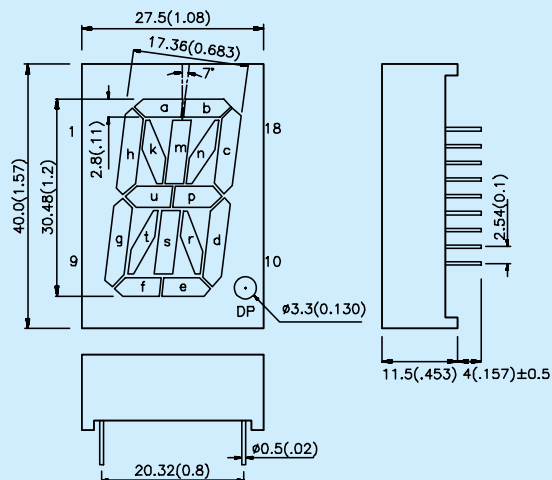

NOTES:
 1. All dimensions are in millimeters(inches).
 2. Tolerance is ±0.25mm(0.01") unless otherwise noted.

PSA/PSC23 Series

38

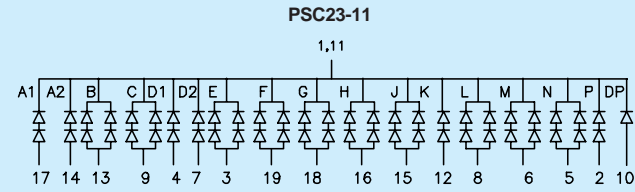
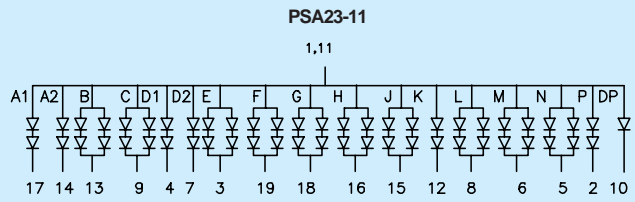
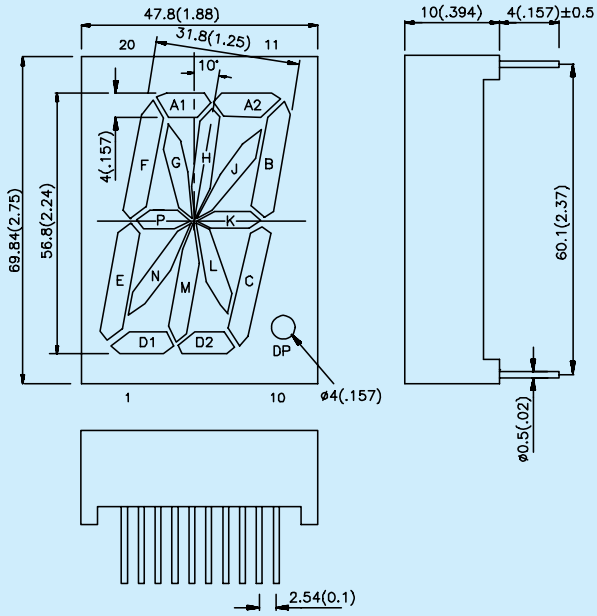

PDA/PDC54 Series

39

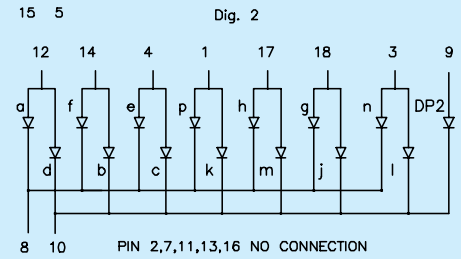
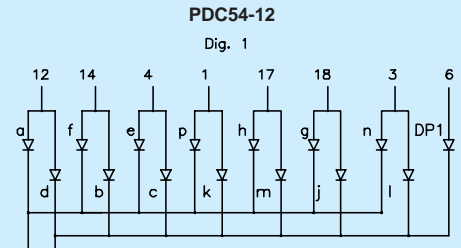
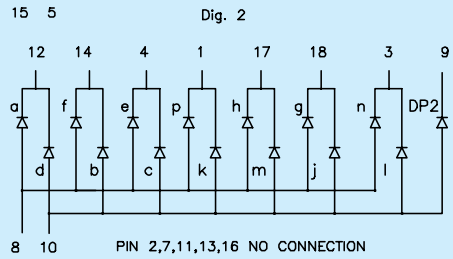
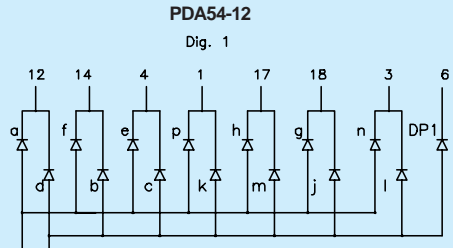
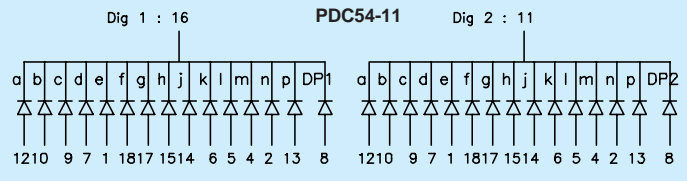
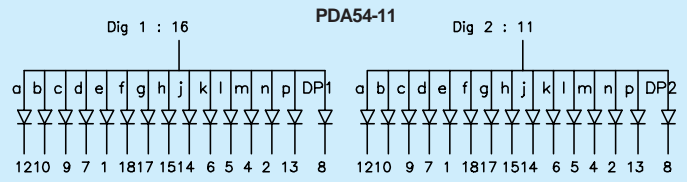
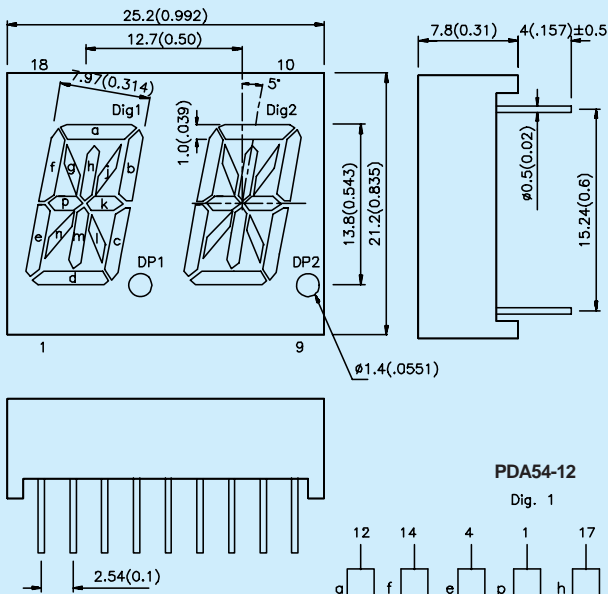

NOTES:
 1. All dimensions are in millimeters(inches).
 2. Tolerance is ±0.25mm(0.01") unless otherwise noted.

TA/TC07 Series

40

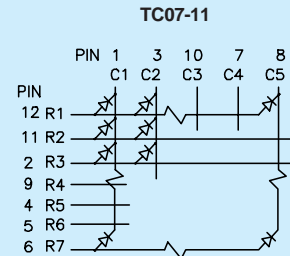
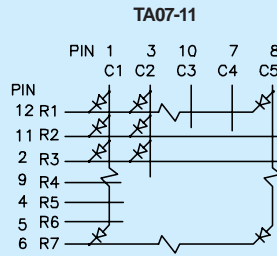
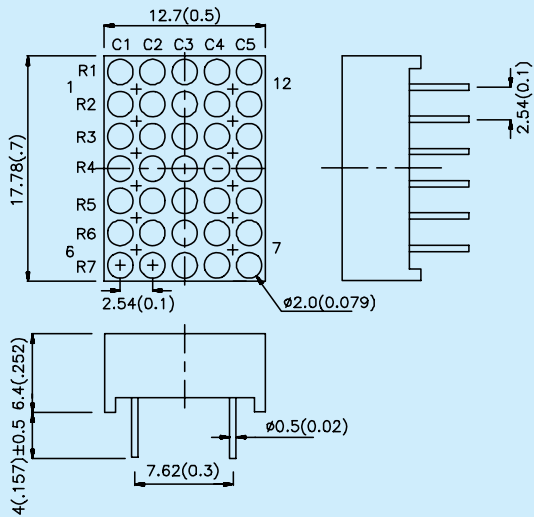

TA/TC08 Series

41

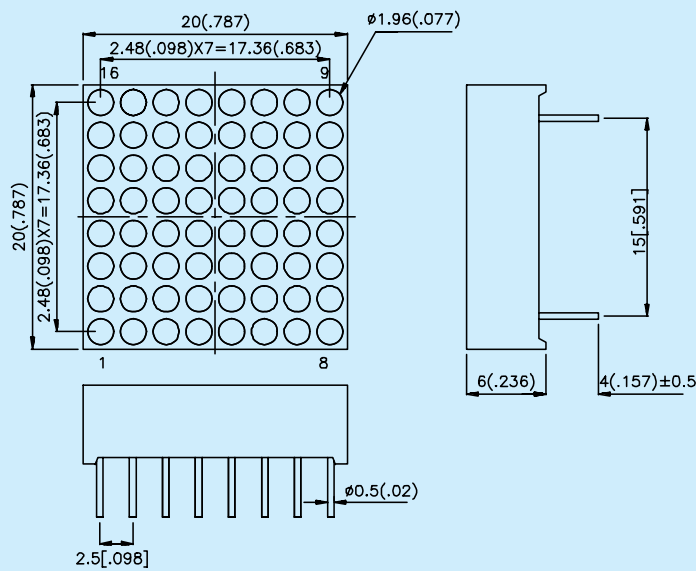

TA08-81

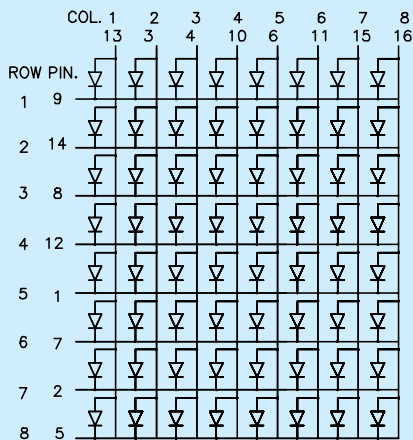

TC08-81

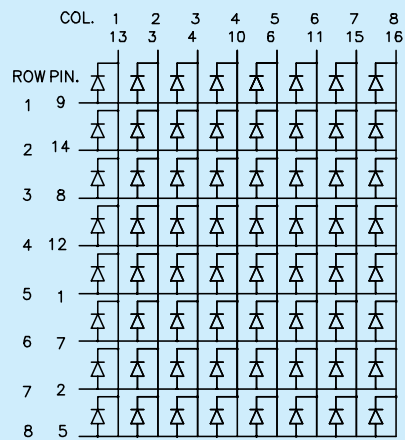

NOTES:
 1. All dimensions are in millimeters (inches).
 2. Tolerance is ±0.25mm (0.01") unless otherwise noted.

TA/TC12-11

TBA/TBC12-11

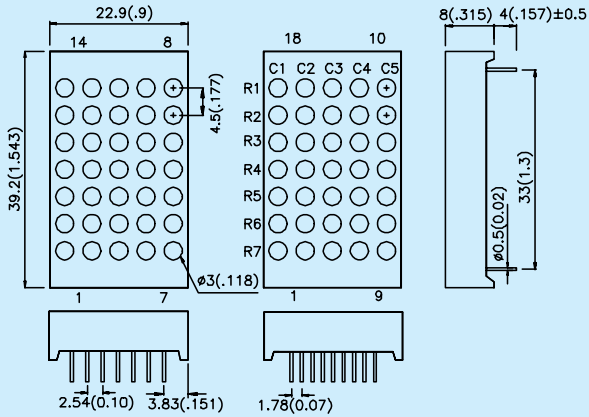

TA12-11

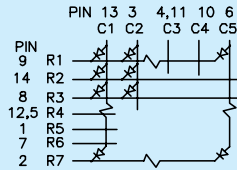

TC12-11

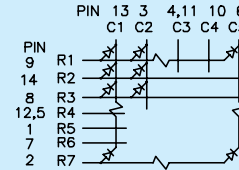

TBA12-11

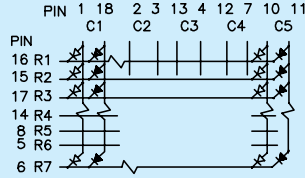

TBC12-11

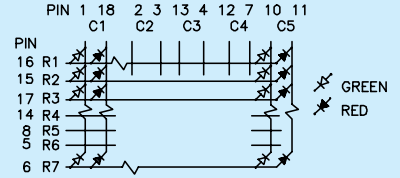

TBA/TBC12-12

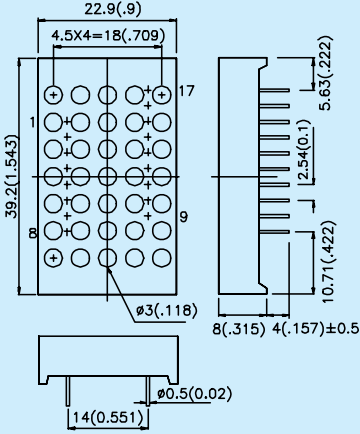

TBA/TBC12-22

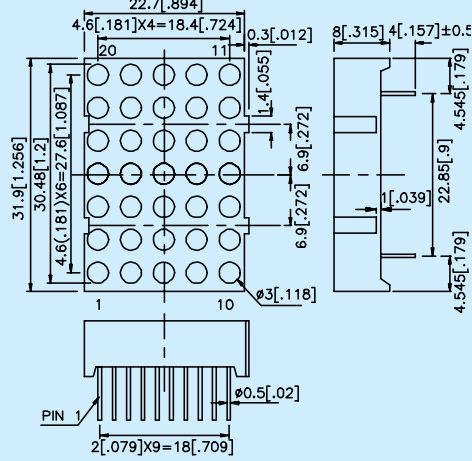

TBA12-22

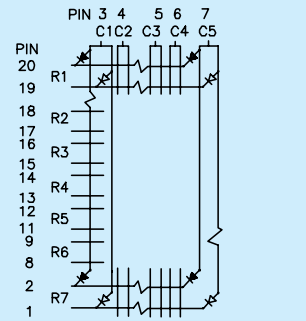

TBC12-22

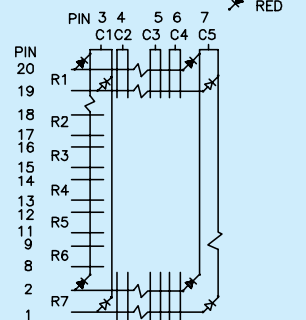

TA/TC12-22

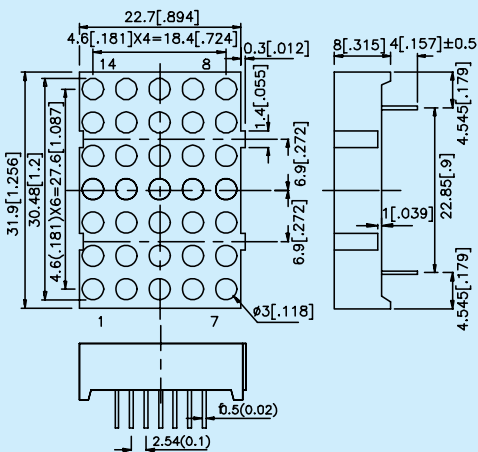

TBA12-12

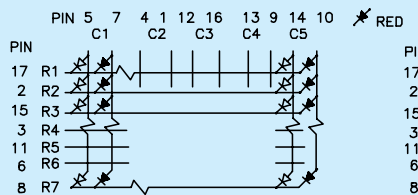

TBC12-12

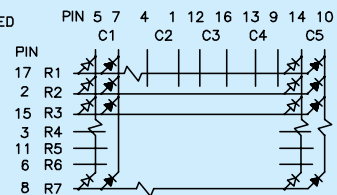

TA12-22

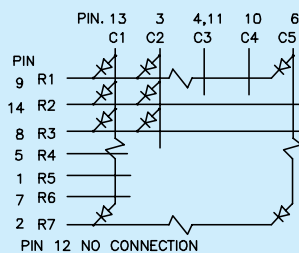

TC12-22

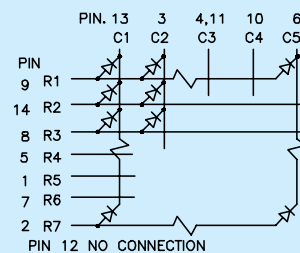

NOTES:
 1. All dimensions are in millimeters (inches).
 2. Tolerance is ±0.25mm (0.01") unless otherwise noted.

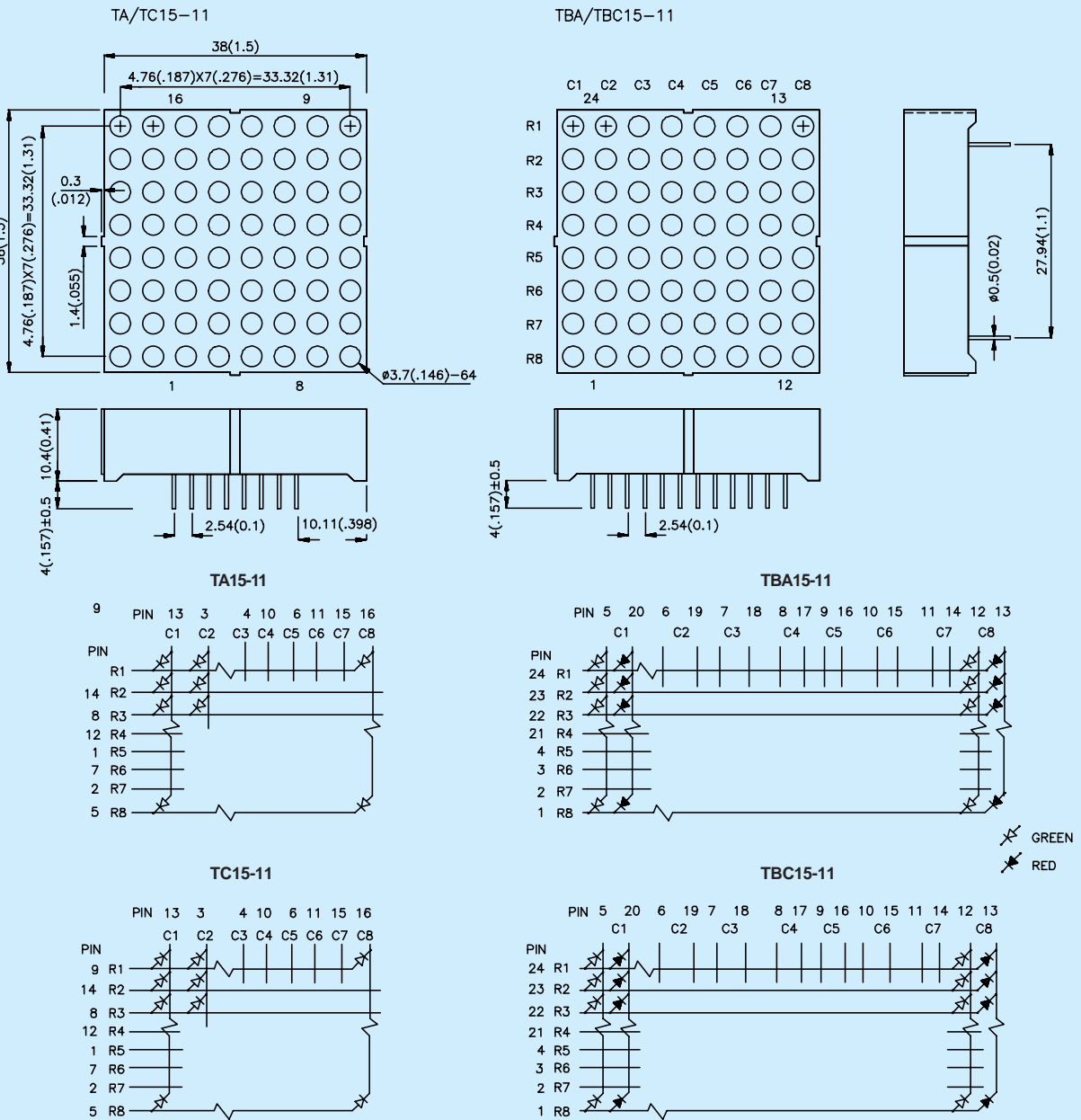
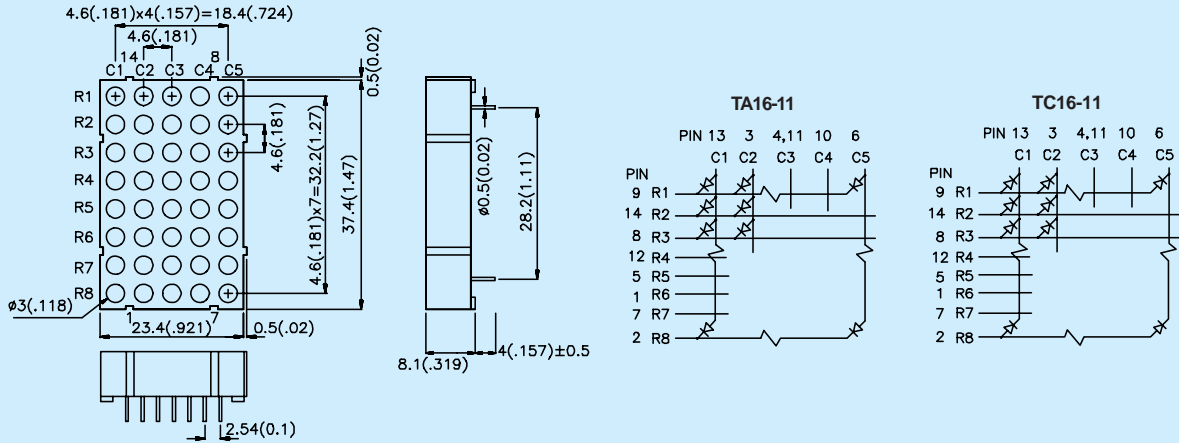

NOTES:
 1. All dimensions are in millimeters (inches).
 2. Tolerance is $\pm 0.25\text{mm}$ ($0.01''$) unless otherwise noted.

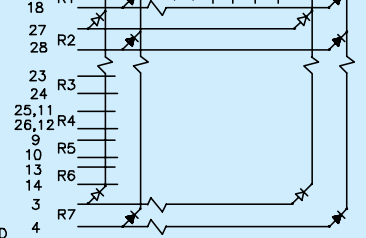
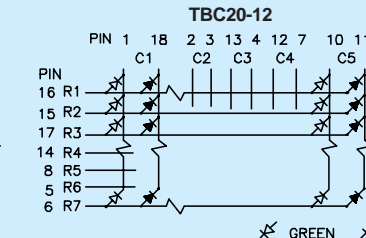
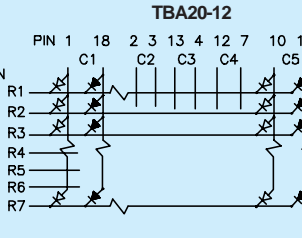
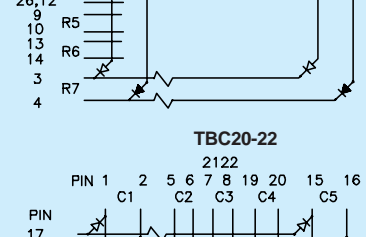
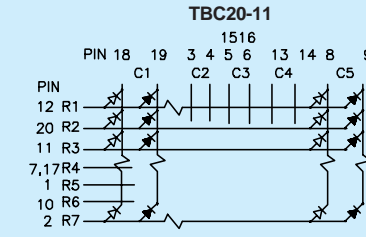
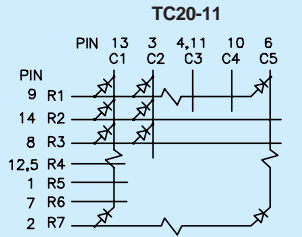
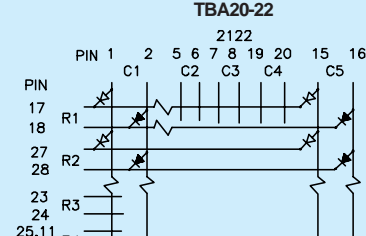
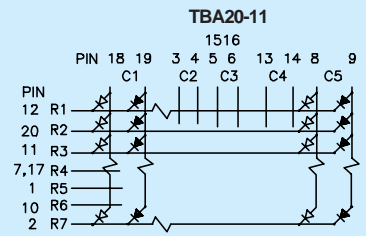
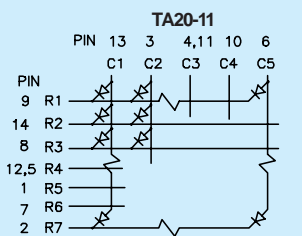
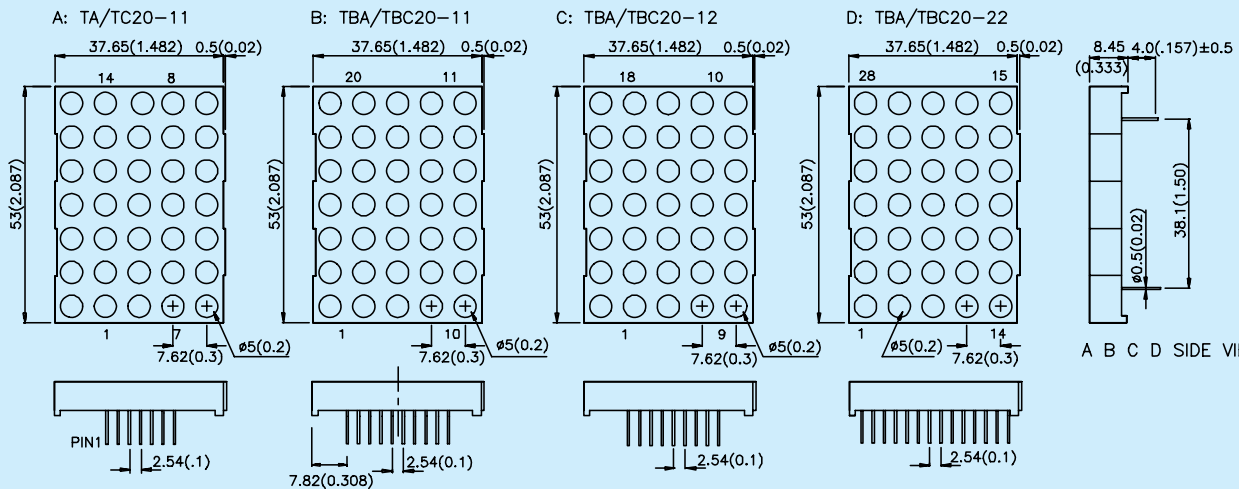
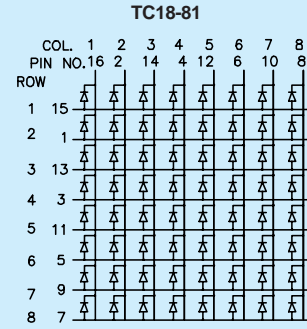
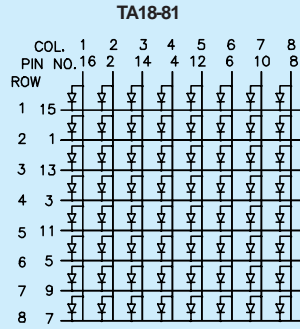
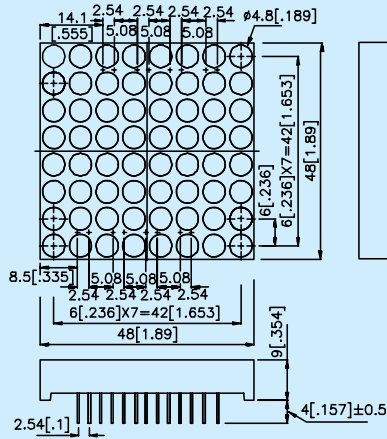

GREEN RED

NOTES:
 1. All dimensions are in millimeters (inches).
 2. Tolerance is ±0.25mm (0.01") unless otherwise noted.

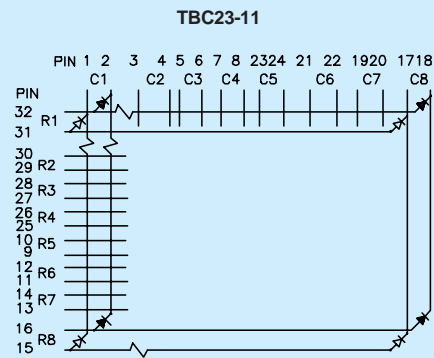
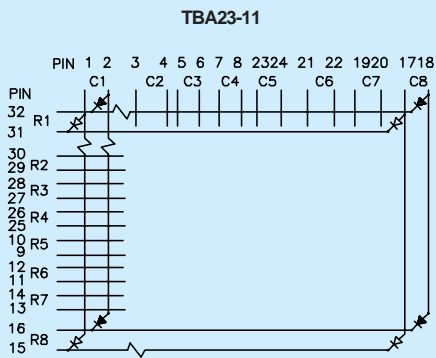
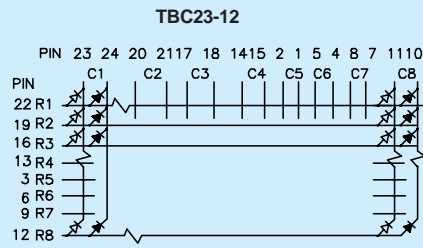
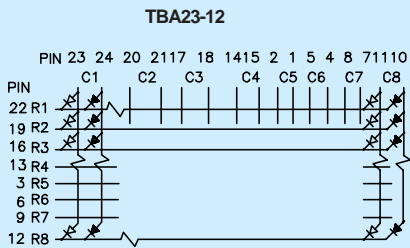
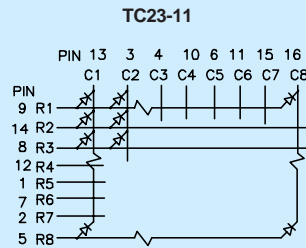
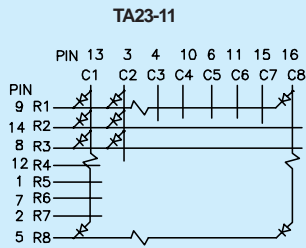
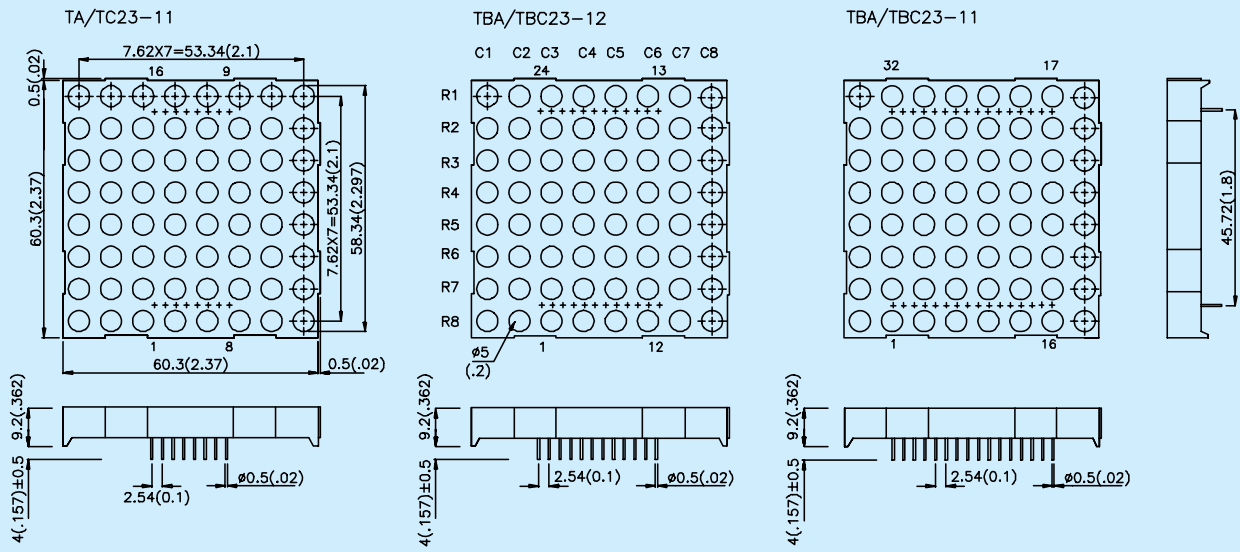

✕ GREEN
✕ RED

NOTES:
1. All dimensions are in millimeters (inches).
2. Tolerance is $\pm 0.25\text{mm}$ ($0.01''$) unless otherwise noted.

TA/TC24, TBA/TBC24 Series

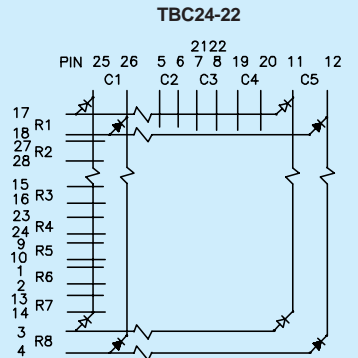
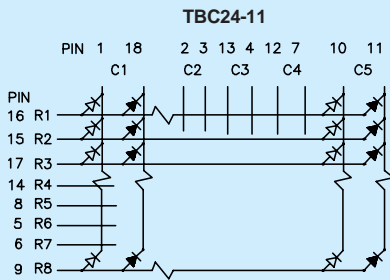
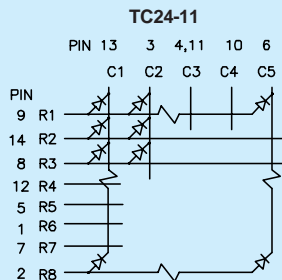
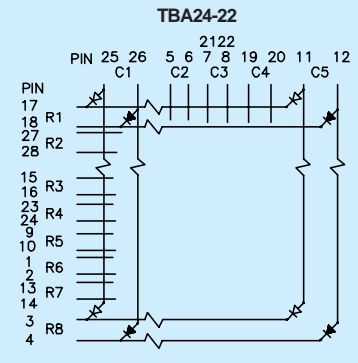
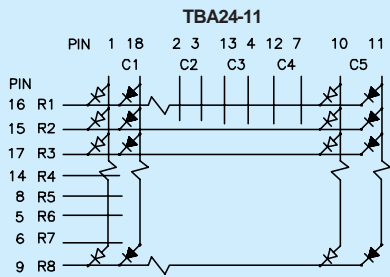
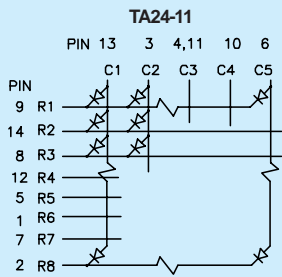
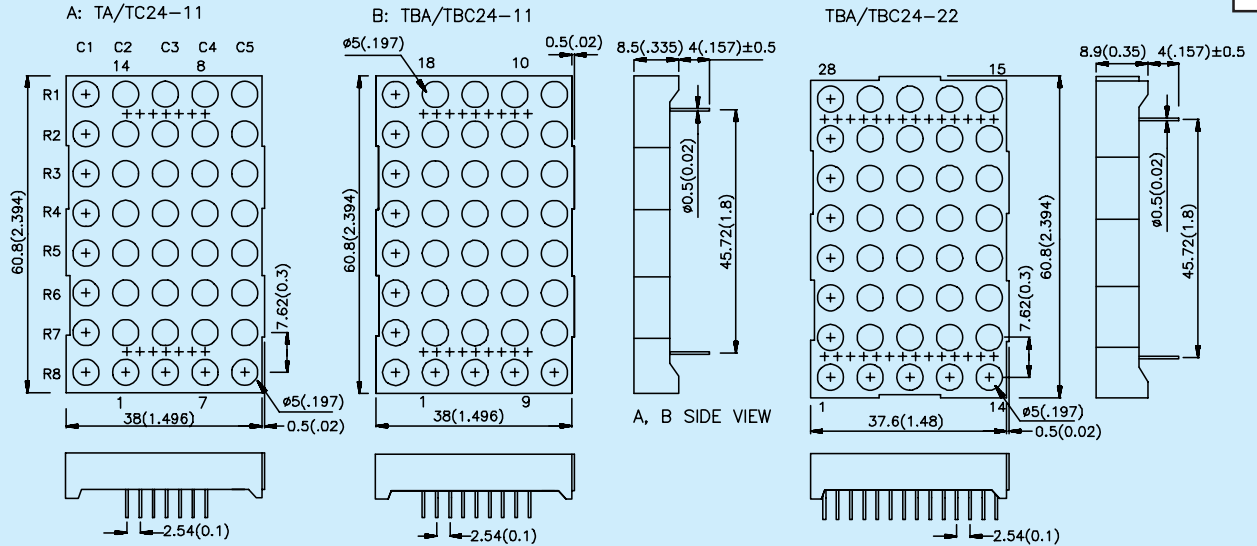

GREEN
 RED

TA/TC30 Series

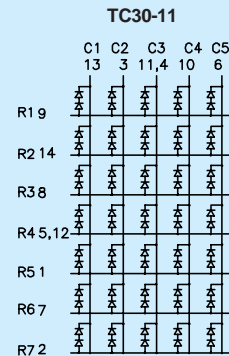
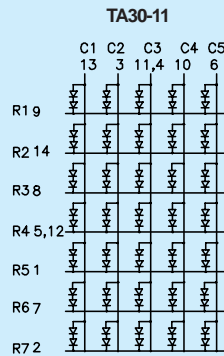
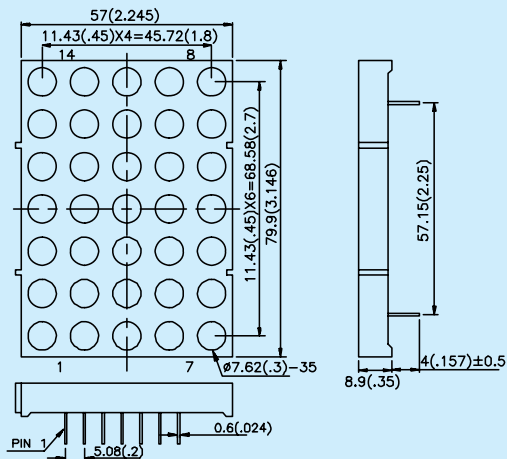

NOTES:
 1. All dimensions are in millimeters(inches).
 2. Tolerance is ±0.25mm(0.01") unless otherwise noted.

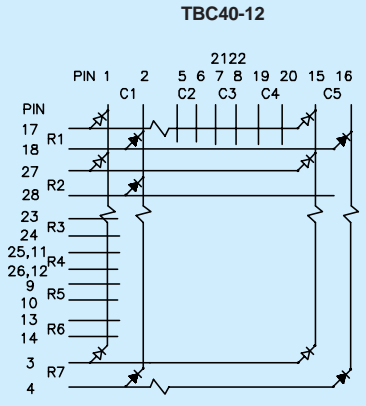
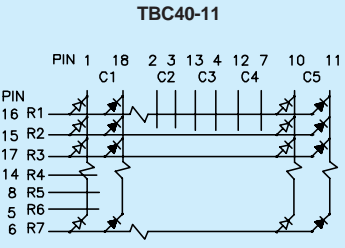
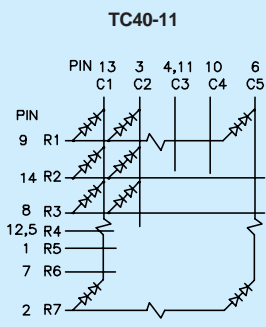
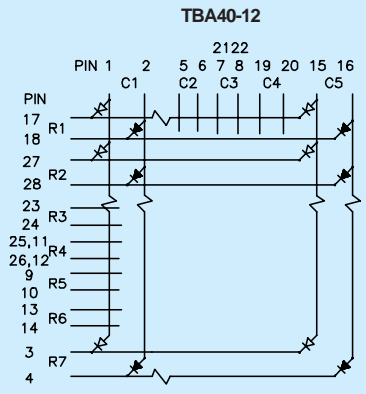
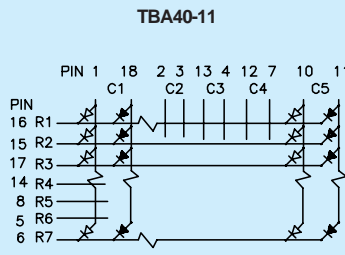
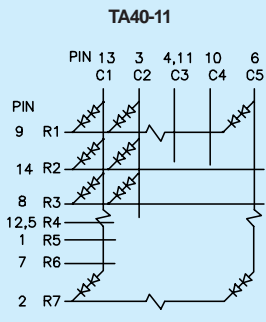
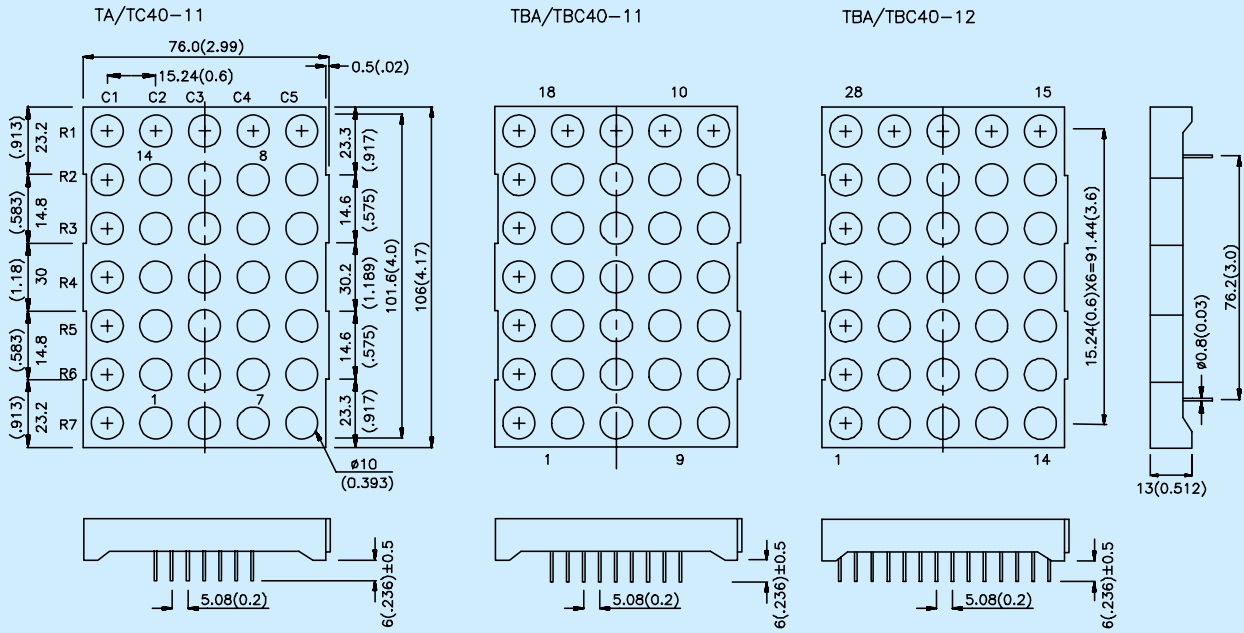

✱ FOR 2 RED CHIPS

✱ FOR 2 GREEN CHIPS

NOTES:
 1. All dimensions are in millimeters(inches).
 2. Tolerance is ±0.25mm(0.01") unless otherwise noted.